

ESSE

Wall-mounted Gas Fires

41 & 48 Landscape



INSTALLATION, USER & SERVICING INSTRUCTIONS
(TO BE LEFT WITH THE CUSTOMER)

UK & IRELAND

UK

IE

CE

INSTALLATION INSTRUCTIONS

CONTENTS

<u>Important Notes</u>	<u>Page 2</u>	<u>Commissioning the Heater</u>	<u>Page 15</u>
<u>Technical Information</u>	<u>Page 4</u>	<u>Customer Briefing</u>	<u>Page 22</u>
<u>Dimensions</u>	<u>Page 5</u>	<u>Commissioning Checklist</u>	<u>Page 23</u>
<u>Installation</u>	<u>Page 5</u>	<u>Servicing Instructions</u>	<u>Page 24</u>

IMPORTANT NOTES

This is a high efficiency, flueless catalytic, live flame effect heater. It provides radiant and convected heat, both efficiently and safely utilising the latest type of catalytic convector burner technology. It is recommended only as a secondary heat source.

Before installation, ensure that the local distribution conditions identification of the type of gas and pressure and the adjustment of the heater are compatible. Refer to the data label, visible when the front is removed (Figure 3).

If the heater is to be used for Propane, the M8 aeration screw should be fitted. If the heater is to be used for Butane, or Butane/Propane mix or Natural Gas this aeration screw MUST NOT BE FITTED (Figure 10).

This heater has either a manually controlled gas valve which can be adjusted by the control knob on the front of the gas valve, located on the lower right hand side of the heater behind the front panel or a remote controlled valve operated via a handset.

This heater incorporates a combustion monitoring system (ODS). It must not be adjusted or put out of operation. If replaced then manufacturers original parts must be used.

The heater is designed to fit various types of situations as listed in the Installation Requirements.

This heater must be installed in accordance with these instructions and with the rules in force and only used in a sufficiently ventilated space. A minimum of 100cm² purpose provided ventilation is

required for this appliance. An openable window or equivalent is also required. The room size should be a minimum of 30m³ (1059ft³) for the 41 Landscape model and a minimum 40m³ (1412ft³) for the 48 Landscape model. This volume may include adjacent spaces but these spaces must not be separated by a door.

The heater must not be installed in a bedroom, bathroom or any sleeping area.

Additionally for LPG, the heater must not be used in cellars or basements. The heater does not require a flue system of any type as the catalytic converter cleans the flue products to provide a complete combustion system.

The heater must be installed by a competent person in accordance with Gas Safety (Installation and Use) Regulations 1998 or rules in force. In particular, as the gas supply pipe may well be concealed within a wall, attention is drawn to regulation 19 'Enclosed Pipes'. It is strongly recommended that a GAS SAFE registered engineer is used for this purpose, as they are the only persons approved by the HSE under the above regulations.

On initial light up of a new heater, the 'newness' will burn off within the first few hours of operation. During this period some smoke may be emitted from the outlet grille, this should be no cause for concern. Accordingly, the room should be well ventilated with all windows and doors open during this period.

All surfaces except the controls are considered to be working surfaces.

Table 1 41 Landscape Technical Data

GAS	NATURAL GAS (G20)	PROPANE (G31)	LPG Butane (G30)/Propane (G31)
CATEGORY	I ₂ H	I ₃ P	I ₃ B/P (30)
HEAT INPUT (GROSS) MAX	2.6Kw	2.6kW	2.6kW
HEAT INPUT (GROSS) MIN	1.7Kw	1.9kW	1.75kW
SUPPLY PRESSURE	20 mbar	37mbar	30mbar
BURNER PRESSURE HIGH	19.8 mbar ±0.5 mbar	36.4 mbar ±0.5 mbar	27.0 mbar ±1.0 mbar
BURNER PRESSURE LOW	10.5 mbar ± 0.5 mbar	23.0 mbar ±0.5 mbar	11.5 mbar ±0.5 mbar
INJECTOR SIZE	3/160	7/75	7/75
GAS CONNECTION	8mm O.D. Tube	8mm O.D. Tube	8mm O.D. Tube
GAS CONSUMPTION (HIGH)	0.23m ³ /h	0.1m ³ /h	0.076m ³ /h
OXYPILOT	SEAGAS NG 441	SEAGAS LPG 451	SEAGAS LPG 451

Table 2 48 Landscape Technical Data

GAS	NATURAL GAS (G20)	PROPANE (G31)	LPG Butane (G30)/Propane (G31)
CATEGORY	I ₂ H	I ₃ P	I ₃ B/P (30)
HEAT INPUT (GROSS) MAX	3.5kW	3.5kW	3.5kW
HEAT INPUT (GROSS) MIN	2.3kW	2.3kW	2.3kW
SUPPLY PRESSURE	20 mbar	37 mbar	30 mbar
BURNER PRESSURE HIGH	19.5 mbar ± 0.5 mbar	36.8 mbar ± 0.5 mbar	29 mbar ± 1.0 mbar
BURNER PRESSURE LOW	9.2 mbar ± 0.5 mbar	18.4 mbar ± 0.5 mbar	13.1 mbar ± 0.5 mbar
INJECTOR SIZE	7/220	7/100	7/100
GAS CONNECTION	8mm O.D TUBE	8mm O.D TUBE	8mm O.D TUBE
GAS CONSUMPTION (HIGH)	0.31m ³ /h	0.13m ³ /h	0.078m ³ /h
OXYPILOT	SEAGAS NG 441	SEAGAS LPG 451	SEAGAS LPG 451

DIMENSIONS

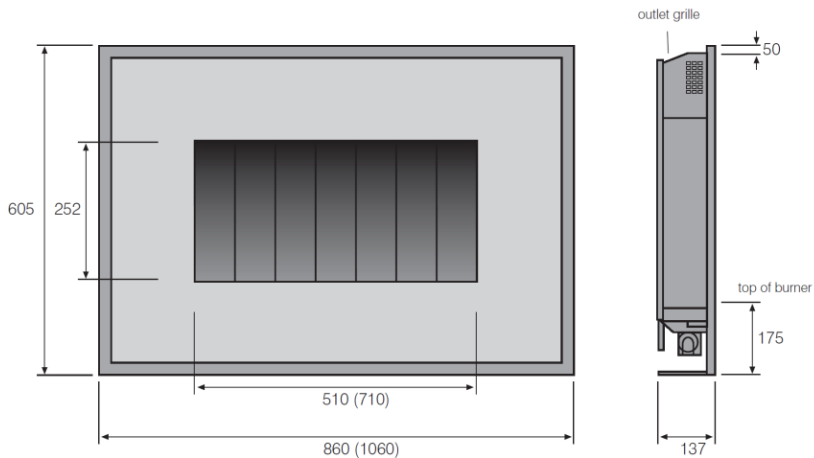

ALL MEASUREMENTS IN MM. SIZES ARE APPROXIMATE ONLY. VARIATIONS MAY OCCUR IN MANUFACTURE.
DIMENSIONS SHOWN ARE FOR WIDESCREEN 41" WITH WIDESCREEN 48" DIMENSIONS IN BRACKETS.

Figure 1 41 & 48 Landscape Firewall Dimensions

INSTALLATION

This heater is designed to be wall mounted. The wall should be reasonably flat and of a sufficient size to accommodate the heater (see Figure 1). If the appliance is to be sited near a disused natural draught flue, it is recommended that the old flue should be partially sealed off to prevent draughts however some ventilation will be required to prevent condensation.

ROOM SIZING

The room size should be a minimum of 30m³ (e.g. 12' x 12' x 7'6) for the Widescreen 41" model and a minimum of 40m³ (e.g. 14' x 14' x 7'6) for the Widescreen 48" to allow adequate circulation of air and ensure the correct operation of the heater. This volume may include adjacent spaces but these spaces must not be separated by a door.

SITE REQUIREMENTS

This heater may be installed in any room in a home: however there are exception and the heater may not be used in bedrooms, bathrooms or shower rooms. Additionally for LPG, the heater must not be used in cellars or basements.

Installations in living rooms and conservatories are popular, other rooms such as kitchens, dining rooms and hallways are permitted, providing a suitable gas supply is available, and the room sizing and ventilation requirements are adhered to.

The heater is designed to be versatile, and as such will operate correctly when exposed to normal gentle draughts experienced within the home. It is not recommended, however that the heater be installed in areas where it is likely to be exposed to persistent strong draught, that may be generated by outside doors, windows or air vents. It is recommended that the heater should not be installed within 1m of any air vent.

CLEARANCES TO NON-COMBUSTIBLES

Non-combustible surfaces are defined as brick, metal, marble, concrete etc., and also a number of man-made materials impervious to flame. If in doubt refer to the material manufacturer for further information, before proceeding with installation.

It is recommended that there is at least 400mm (16") clearance above the outlet grille.

Minimum clearance from the bottom of the outer frame to the floor must be 90mm (3.5").

Clearance to the sides of the heater is 50mm (2"), however, clear and easy access to the controls located on the lower right hand side of the heater behind the front panel on the right hand side must be allowed for, and we would therefore recommend that at least 100mm (4") be allowed.

Clearance to the front of the heater is 500mm (2ft). Care must be taken that no brickwork or other incombustible material protrudes into the area immediately around the base of the heater or area underneath the heater in a way that is likely to affect natural airflow into or around the heater.

CLEARANCES TO COMBUSTIBLE MATERIALS

Combustible materials are defined as wood, fabrics, or other materials likely to combust if exposed to flame. Generally, any material, which is likely to discolour, melt or misshape when exposed to moderate heat, should be considered as a combustible material of surface. Any fire surround or shelf to be used in conjunction with this heater should be rated at a minimum of 100°C otherwise discolouration or smells may occur. If in doubt refer to the shelf manufacturer.

Minimum clearance from the bottom of the outer frame to the floor must be 90mm (3.5”).

The heater may be mounted directly onto a combustible wall.

Clearance to the sides of the heater is 100mm (4”) but curtains, drapes and other fabrics are not permitted within a distance of 500mm (20”) of the heater sides. No such materials are permitted directly above the heater regardless of distance.

Clearance to the front of the heater is 1000mm (39in).

The minimum clearance to the ceiling above the top of the outer grille must be at least 1067mm (42”)

A combustible shelf may be fixed to the wall above the heater, providing that it complies with the dimensions given below



WARNING

Under no circumstances must any electrical device (e.g. Flat Screen T.V.) be wall mounted above this fire.

The shelf depth may be increased up to a maximum of 457mm (18”) but the height must also be increased accordingly. An increase in height of 25mm is required for every 12.5mm of additional shelf depth. For shelves that are too low, protective devices can be used such as metal heat deflectors, but it must be assured that the shelf does not reach an unacceptable temperature before relying on such a solution.

Table 3 Dimensions for Combustible Shelves

Maximum depth of shelf	Minimum distance from top of outlet grille to underside of shelf
75mm (3 inches)	305mm (12 inches)
150mm (6 inches)	457mm (18 inches)
457mm (18 inches)	1067mm (42 inches)

As with all heating appliances, any decorations, soft furnishings, and all coverings (i.e. flock, blown vinyl and embossed paper) positioned too close to the heater may discolour or scorch.

VENTILATION

A minimum of 100cm² purposely provided ventilation is required for this heater. An openable window of equivalent is also required. The requirements of any other flued appliance operating in the same room or space must be taken into consideration when assessing ventilation.

Any ventilation fitted must comply with BS 5871 and BS 5440 part 2. Ventilation fitted under, or within immediate vicinity of the heater must not be used as it may adversely affect performance of the ODS system.

For Republic of Ireland, see relevant rules in force and I.S.813.

SECURING THE HEATER TO THE WALL

Select a suitable site for the heater.

Remove the front of the heater by lifting the panel, as shown in Figure 2

Remove the glass frame securing nuts and remove the glass frame complete, by tilting the base of the frame out and lifting upwards. Store the glass frame and nuts somewhere safe.

Remove the wall plate (4 x M5 nuts), the burner, and the igniter from the heater body, see Figure 3

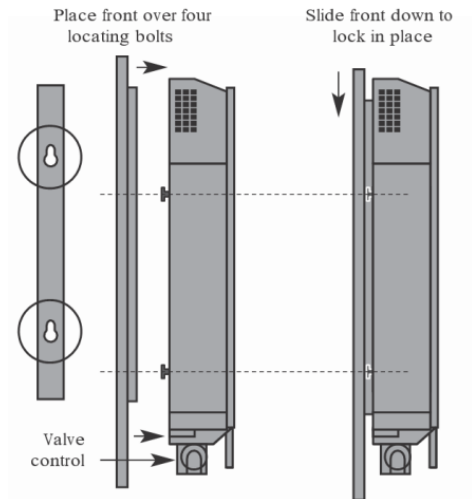

Figure 2 Fitting the Front Panel

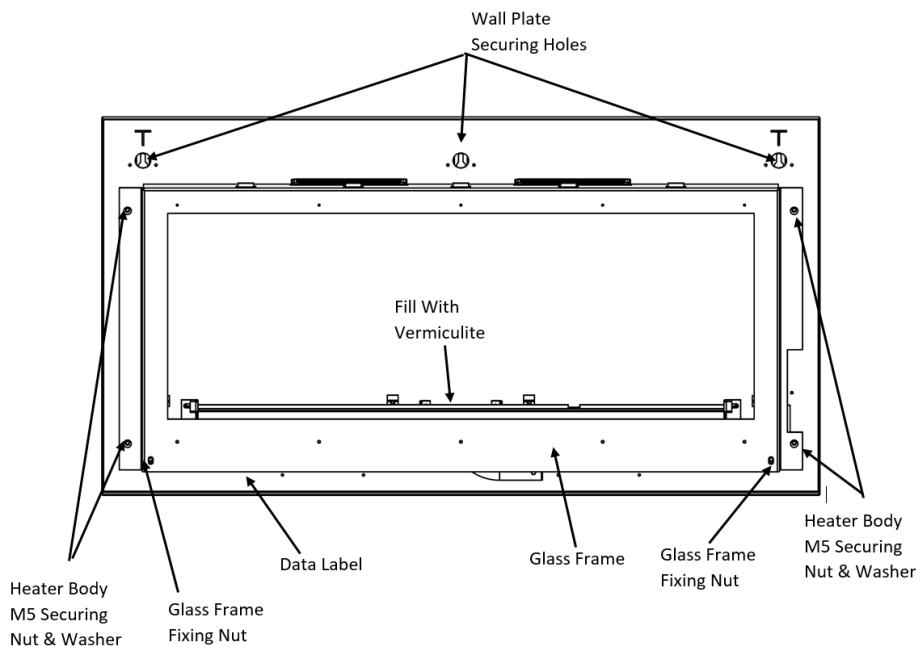

Figure 3 Heater Mounting Points

Mark the position of the four Wall Fixing Points using the wall plate as a template, Figure 4 and Figure 5 for the 41 Landscape Heater and 48 Landscape Heater respectively.

Drill and plug the wall with suitable wall plugs. Secure the wall plate to the wall using suitable screws ensuring the wall plate is level. Secure the heater body to the wall plate using the M5 nuts and washers provided.

If fitting using the optional floor stand ensure that the fire is mounted to the wall with 125mm between the bottom of the casing and the floor, see Figure 6.

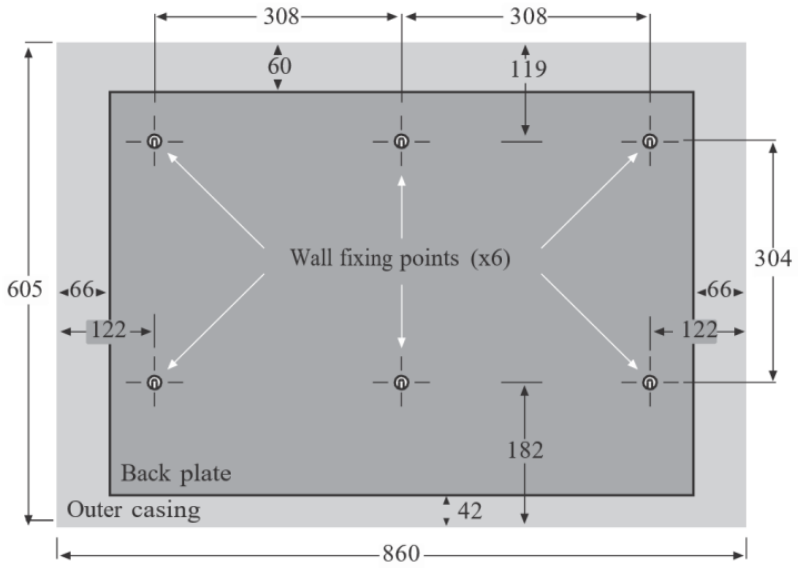

Figure 4 Wall Mounting Points for 41 Landscape Heater

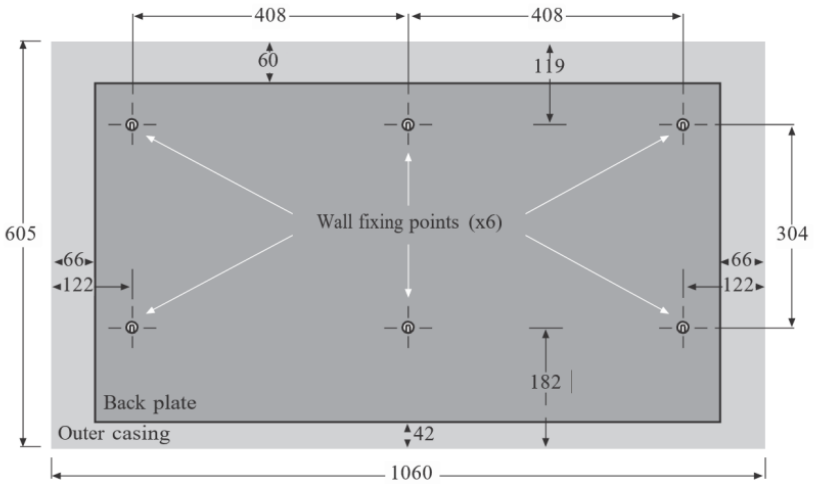

Figure 5 Wall Mounting Points for 48 Landscape Heater

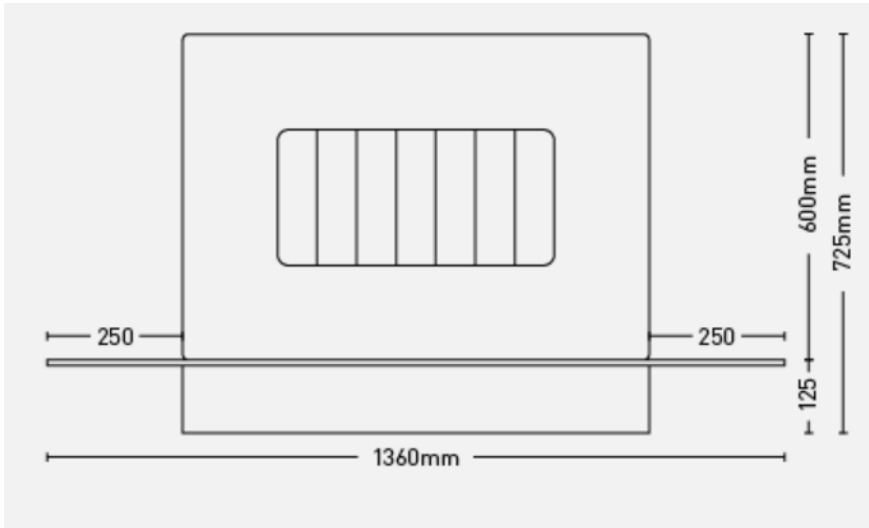

Figure 6 Dimensions for Fitting the Heater with the Optional Floor Stand

GAS CONNECTION

The gas inlet connection is located on the gas valve underneath the heater at the right hand side. The gas supply may connect to the heater over the surface of the wall or by concealed connection below the heater. Concealed pipes should not be routed through walls without being protected by sleeving or conduit. No more than 2.5m of 8mm diameter pipe must be used to avoid unnecessary pressure drops.

An isolation tap should be provided on the gas inlet to the heater.

If a concealed gas connection is to be made, the supply pipe should always be sleeved through walls and floors using the shortest possible route.

When making the gas connection ensure that the front panel will not foul the pipe or isolation tap. If the heater is to be operated on propane, the M8 aeration screw should be fitted. If the heater is to be operated on Butane or Butane/Propane mix this aeration screw **MUST NOT BE FITTED** see Figure 10.

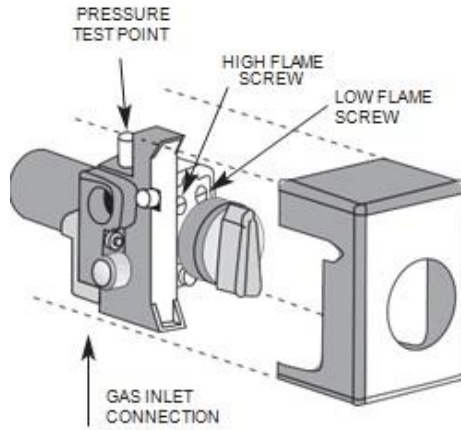

Figure 7 Manual Valve

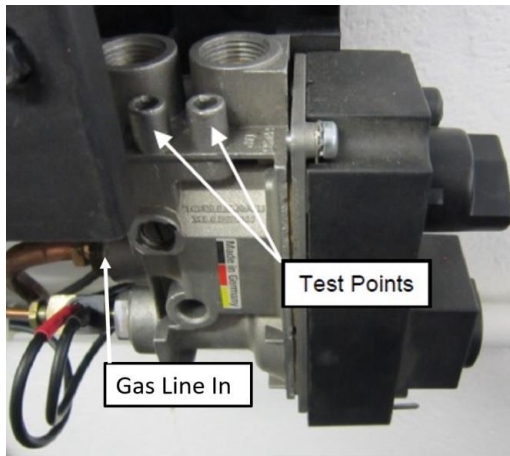

Figure 8 Remote Valve

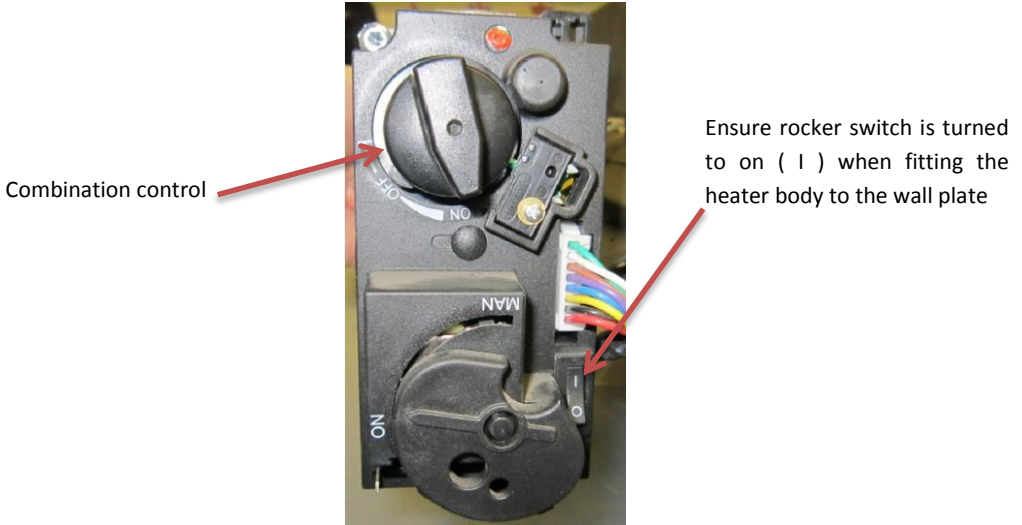

Figure 9 Remote Valve Controls

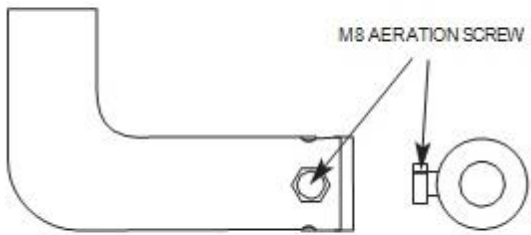

Figure 10 Aeration Screw Location

FITTING THE VERMICULITE GRANULES

Pour the vermiculite granules into the burner. Fill the burner completely to the top as shown in Figure 3.

Do not overfill the vermiculite over the top of the burner in the area of the pilot flame.

Replace the frame and secure using the 2 nuts previous removed.



NOTE

Under no circumstances should the heater be operated with the glass frame removed or the glass damaged or without the vermiculite granules.

COMMISSIONING THE HEATER

MANUAL BURNER

The heater is fitted with a pilot light, which is also an oxygen depletion sensor (O.D.S), piezo spark, and flame sensing device. The control is located behind the front panel on the right hand side of the heater. The pilot light is located at the right hand end of the burner.

Should the heater be extinguished for any reason wait 3 minutes before re-ignition is attempted.

To check the outlet pressure, pull the control valve plastic cover forward and remove it (Figure 7). Slacken the pressure test point sealing screw and connect a suitable pressure gauge to the pressure test point (Figure 7).

LIGHTING THE PILOT

Depress control knob fully. Whilst depressed turn knob slowly anti-clockwise to 'PILOT' setting.

A click will be heard and the spark should light the pilot, repeat until pilot is visibly lit. The operation of the spark can be viewed on the pilot assembly at the right hand end of the burner.

Keep knob depressed at this point for 10 - 15 seconds and release the knob slowly. Preferably the pilot should be left to stabilise for approximately 5 minutes before igniting the burner.

HIGH SETTING

If the pilot is not already lit, light the pilot as described above.

With control knob at 'PILOT' setting, depress and turn anti-clockwise to the 'HIGH' setting and release the knob. After a few seconds the burner will light on high setting.

Check that the high burner pressure is in accordance with that given in the TECHNICAL INFORMATION section. The pressure is factory set and should not require adjustment but if necessary adjust the HIGH FLAME SCREW (Figure 7).

LOW SETTING

If the heater is not already lit on the 'HIGH' setting, ignite the heater and set to the 'HIGH' setting as described above. Turn the control knob until the 'LOW' setting is reached. Check that the LOW burner pressure is in accordance with that is given in the TECHNICAL INFORMATION section. The pressure is factory set and should not require adjustment but if necessary adjust the LOW FLAME SCREW (Figure 7).

TURNING THE HEATER OFF

From any heat setting, depress the control knob fully and turn clockwise to 'PILOT' position. Disconnect the pressure gauge, tighten the pressure test point sealing screw and test for gas soundness. Replace the control valve plastic cover.

TURNING THE PILOT OFF

From any heat setting or the 'PILOT' position, depress the control knob fully and turn clockwise to 'OFF' position.

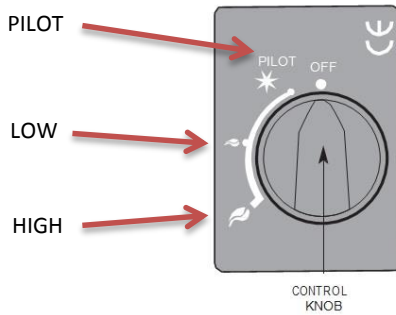

Figure 11 Manual Burner Control

REMOTE CONTROL BURNER

The heater is fitted with a pilot light, which is also an oxygen depletion sensor (O.D.S), piezo spark, and flame sensing device. The control is located behind the front panel on the right hand side of the heater. The pilot light is located at the right hand end of the burner.

Should the heater be extinguished for any reason wait 3 minutes before re-ignition is attempted.

To check pressures, with the outer glass or steel panel removed, slacken the pressure test points sealing screws and connect a suitable pressure gauge to the pressure test points (Figure 8).

BATTERY FITMENT

Insert the supplied 9V battery in the handset and the four supplied 1.5V AA batteries in the receiver as shown in Fig 8A & 8B

Ensure the remote valve is set according to Figure 9 before set up.

BATTERY FITMENT

Insert the supplied 9V battery in the handset and the four supplied 1.5V AA batteries in the receiver as shown in Figure 12 & Figure 13.



Figure 12 Handset Battery Fitting



Figure 13 Receiver Battery Fitting

SETTING THE ELECTRONICS CODE

The heater comes with the handset and receiver already paired as part of our in house quality checks. If the handset does need to be paired, please follow the instructions below.



Figure 14 Remote Handset



Figure 15 Receiver

Small flame button

Reset button

A code is selected automatically for all Mertik Maxitrol electronics from among 65000 random codes available. The receiver has to learn the code of the handset.

Press and hold the receivers reset button until you hear two beeps. The first beep is short and the second beep is long. After the second beep, release the reset button.

Within the subsequent 20 seconds, press the small flame button on the handset until you hear two additional short beeps confirming the code is set. If you hear one long beep then this indicates the code learning sequence has failed or the wiring is incorrect.



NOTE

This is a one-time setting only and is not required after changing the batteries in the handset or receiver.



When lighting the burner with the remote control, if the ON/OFF switch is not turned on (fig 6C) the unit will issue one long continuous beep.

HANDSET OPERATION



Figure 16 Handset Operation

FITTING THE OPTIONAL FLOOR STAND & TOP GRILLE

Ensure that the heater has been fitted to the heights shown in Figure 6.

The optional floor stand can now be placed under the heater and centralized.

FITTING THE FRONT PANEL

The front panel can now be fitted by aligning the large hole on the keyway holes with the fixing screws and sliding the front panel down.

The fixing screws can be adjusted to ensure a good fit that will allow the panel to be fitted & removed but without allowing the panel to be loose and have excessive movement.

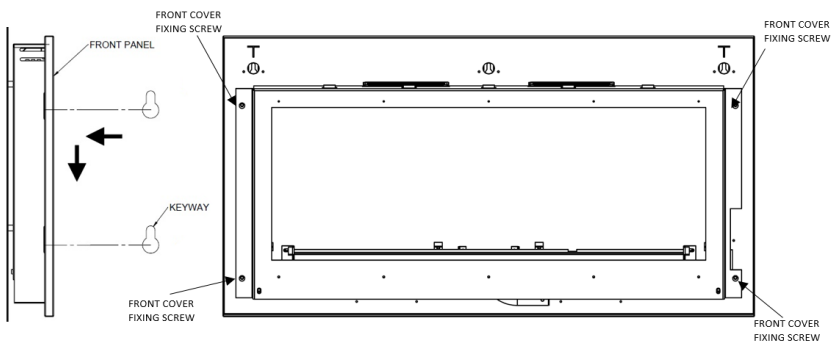

Figure 17 Fitting the Front Panel

To remove the front panel, reverse the fitting procedure.

- Advise the customer how to use the heater.
- Advise the customer that the pilot light should be left on even if the main burner is switched off.
- Point out that the operating procedure is in the User Instructions.
- Explain to the customer that the heater has a flame sensing and oxygen depletion monitoring system.
- Point out the explanation of this system in the User Instructions.
- Advise that if the monitoring system repeatedly shuts off the heater, it should be switched off and a specialist consulted.
- Advise that if the heater goes out for any reason, wait at least 3 minutes before re-lighting.
- Advise the customer that due to newness of materials the heater may give off a smell for a period of time after commissioning and that this is quite normal and any odours should disappear after a few hours operation.
- Advise the customer that the heater should not be used if the glass becomes damaged or without vermiculite granules.
- Stress that no coals or logs must be added to the heater and that any replacement parts must only be authorised ESSE spares.
- Recommend that the heater is regularly serviced at least once a year by a qualified person.

COMMISSIONING CHECKLIST

To assist with any potential guarantee claim please complete the following information:-
To be completed by the installer.

Dealer the appliance was purchased from:

Name:

Address:

Telephone No:

ESSENTIAL information:

Date Installed

Model Description:

Serial No:

Installation Engineer:

Company Name:

Address:

Telephone No:

Commissioning Checks – to be completed and signed:

Has the use of the appliance, operation and controls been explained?	Yes	<input type="checkbox"/>	No	<input type="checkbox"/>
Clearance to combustible materials checked?	Yes	<input type="checkbox"/>	No	<input type="checkbox"/>
Instruction book handed to the customer?	Yes	<input type="checkbox"/>	No	<input type="checkbox"/>
CO Alarm fitted?	Yes	<input type="checkbox"/>	No	<input type="checkbox"/>

Signature:.....

Print Name:.....

SERVICING INSTRUCTIONS

The heater is fitted with a pilot light and flame-sensing device which is also an oxygen depletion sensor (O.D.S). This is not adjustable and must not be put out of action. If any parts of this system requires replacement only original manufacturers parts must be used.

The following servicing procedure should be carried out regularly and only by a qualified person.

1. Ensure that the heater is turned off and is cold.
2. Remove the front panel, glass frame securing nuts and the glass frame Fig.2)
3. Carefully remove any deposits of dirt, lint etc., from the vermiculite burner bed, aeration holes and pilot assembly with a soft brush. Do not use a vacuum cleaner near the vermiculite burner bed.
4. Clean the pilot aeration 'hole'.
5. Inspect the catalyst for sign of damage and dirt. The expected life of the catalyst is in excess of 11,000 hours (10 years of normal use). After this time the catalyst should be replaced. If there are any deposits of dirt or soot on the catalyst clean with a soft brush and a vacuum cleaner.
6. Due to high temperatures reached within the heater, surface cracks may appear on the back board behind the flames. This is quite normal and will not affect the safe operation of the heater. Replace the glass frame.
7. Check the high and low burner setting pressures as described in COMMISSIONING THE HEATER.
8. Check the safe operation of the heater:
If a combustion analyser is available check the combustion performance of the heater as follows:
 - a. Light the heater on HIGH and after 15 minutes check the combustion performance is in accordance with Fig.16 above the catalyser.
 - b. If the Co figures are more than given in Fig.16 this suggests that the catalyser is due for changing or the aeration holes on the burner require or new vermiculite granules are required. Turn off the heater investigate and correct.
9. Check that the purpose provided air vent is non-obstructed.

Table 4 Combustion Performance Limits

	Above Catalyzer
Co ppm	Less than 10
Co2%	Approx. 3.0-5.0

USER INSTRUCTIONS

CONTENTS

General Notes	Page 25	Operating The Heater	Page 27
Important Notes	Page 25	Combustion Monitoring System	Page 31
Clearances	Page 26	Cleaning	Page 31
Ventilation	Page 27	Servicing	Page 32
Burner Arrangement	Page 27	Guarantee	Page 36

GENERAL NOTES

This heater has been individually designed to add charm and character to your home and provides a highly efficient heat source, coupled with the convenience of clean burning gas. Due to newness of materials the heater may give off a slight smell for a period of time after commissioning. This is quite normal and any odours should disperse after a few hours operation. It is recommended that the heater is used only as a secondary heat source. An electrical appliance such as a television should not be fitted above the appliance. It has been supplied for use on Natural Gas or LPG. The data plate is situated on the Wall Plate (Figure 3)

IMPORTANT NOTES

The installation must be in accordance with National Regulations and must be carried out by a qualified person. Under no circumstances should the appliance be operated without the glass frame attached or the glass damaged. All surfaces except the controls are considered to be working surfaces. Most parts of the heater will get hot during and after use. If young children, the elderly, or infirm are likely to be near the heater a suitable fireguard, conforming to BS8423, is recommended. Do not place any objects on top of the heater. In particular never cover or partially cover the grille. The integral catalyst should be checked by the installer upon servicing to ensure that there are no defects or obstructions. The expected life of the catalyst is in excess of 11,000 hours (10 years of normal use). After this time the catalyst should be replaced. Due to the high temperature reached within the heater, surface cracks may appear on the backboard behind the flames; this is quite normal and will not affect the safe operation of the heater. The room that the heater is installed in must not be used as a bedroom or sleeping area.



Do not use candles or oil lamps. These provide considerable quantities of pollutant and unhealthy soot particles in your home. Smoke from cigarette and cigars contain tarry substances, which may also leave deposits on colder and damp walls when heated.

CLEARANCES

To electrical devices - Under no circumstances must any electrical device (e.g. Plasma T.V.) be wall mounted above a firewall.

To combustibles - Minimum clearance to the sides of the heater are 100 mm (4in) but curtains, drapes and other fabrics are not permitted within a distance of 500 mm (20 in) of the stove sides. No such materials are permitted directly above the heater regardless of distance. Clearance to the front of the heater is 1000 mm (39 in). A combustible shelf may be fixed to the wall above the heater, providing that it complies with the dimensions given below and is rated a minimum of 100°C otherwise discolouration or smells may occur. If in doubt refer to the shelf manufacturer.

The shelf depth may be increased up to a maximum of 457mm (18") but the height must also be increased accordingly. An increase in height of 25 mm is required for every 12.5 mm of additional shelf depth. For shelves that are too low, protective devices can be used such as metal heat deflectors, but it must be assured that the shelf does not reach an unacceptable temperature before relying on such a solution.

As with all heating appliances, any decorations, soft furnishings, and all coverings (i.e. flock, blown vinyl and embossed paper) positioned too close to the appliance may discolour or scorch.

Table 5 Dimensions for Combustible Shelves

Maximum depth of shelf	Minimum distance from top of outlet grille to underside of shelf
75mm (3 inches)	305mm (12 inches)
150mm (6 inches)	457mm (18 inches)
457mm (18 inches)	1067mm (42 inches)

VENTILATION

Purpose provided ventilation of 100cm² is required for this heater. This ventilation must never be blocked or partially blocked. An openable window or equivalent is also required. Ventilation fitted under, or within immediate vicinity of the heater must not be used as it may adversely affect performance of the combustion monitoring system (ODS) system.

The requirements of other appliances operating in the space or room must be taken into consideration when assessing ventilation requirements. This will have been carried out by your Gas Safe registered installer.

A supply of fresh air into the room is advisable to maintain temperatures within limits. The heater **MUST NOT** be installed in a bedroom, bathroom or any sleeping area. Additionally for L.P.G. – the heater must not be used in cellars or basements.

BURNER ARRANGEMENT

The burner should only be used with vermiculite granules as shown in the Installation Instructions. The heater must only be fitted with the vermiculite supplied. **DO NOT** add any extra logs or coals.

OPERATING THE HEATER

The heater is fitted with a pilot light which is also an oxygen depletion sensor (ODS), piezo spark and flame sensing device. The control is located behind the front panel on the lower right hand side. The pilot light is located at the right hand end of the burner.

Should the heater be extinguished for any reason wait 3 minutes before re-ignition is attempted. The heater should not be used at a lower setting than the 'LOW' position.

MANUAL BURNER

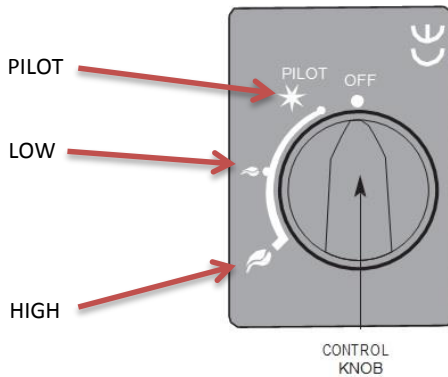

Figure 18 Manual Burner Controls



NOTE

It is recommended that the pilot light be left 'on' even if the main burner is turned 'off'.

LIGHTING THE PILOT

Depress control knob fully. Whilst depressed turn knob slowly anti-clockwise to 'PILOT' setting.

A click will be heard and the spark should light the pilot. Repeat until pilot is visibly lit. The operation of the spark can be viewed on the pilot assembly at the right hand end of the burner.

Keep knob depressed at this point for 10 - 15 seconds and release the knob. Preferably the pilot should be left to stabilise for approximately 5 minutes before igniting the burner.

HIGH SETTING

Ensure that the pilot is lit as described above.

With control knob at 'PILOT' setting, depress and turn anti-clockwise to 'HIGH' setting and release the knob. After a few seconds the burner will light on high setting.

LOW SETTING

With the heater lit on 'HIGH' setting, as described above, output can be decreased by turning the control knob progressively in a clockwise direction until the desired level is achieved, down to the 'LOW' setting.

TURNING THE HEATER OFF

From any heat setting, depress the control knob fully and turn clockwise to 'PILOT' position.

TURNING THE PILOT OFF

From any heat setting or the 'PILOT' position, depress the control knob fully and turn clockwise to 'OFF' position.

REMOTE CONTROL BURNER



Figure 19 Remote Burner Handset



NOTE

When lighting the burner with the remote control, if the ON/OFF switch is not turned on (fig 6C) the unit will issue one long continuous beep.



NOTE

It is recommended that the pilot light be left 'on' even if the main burner is turned 'off'.

BATTERY REPLACEMENT

When the receiver batteries need changing, frequent bleeps can be heard for three seconds when the motor turns.

Ensure the appliance is cold, and remove the receiver box from underneath the appliance and replace the batteries with 4 X 1.5 volts "AA" type quality alkaline batteries.

If the remote control unit ceases to work. The 9 volt battery should be changed with a new 9 volt quality alkaline battery. Replacement is recommended every two years.



NOTE

Mains electrical power is not required as this system runs on batteries only (Alkaline recommended). Battery information: Handset – 1 x 9V block, Receiver – 4 x 1.5V AA.

COMBUSTION MONITORING SYSTEM

This heater is fitted with a combustion monitoring safety device (ODS). If the heater shuts off during use for no apparent reason then several reasons may be suspected. If a door or window has been opened creating a draught, then pilot disturbance could be the problem and removal of the draught should resolve this. The heater can then be re-lit in accordance with the previous section.

If pilot disturbance is not the cause, then the ODS safety system may be in operation. Switch the heater OFF; call in your installer to check the heater and ventilation. Remedial work must be carried out as required. DO NOT allow the heater to be used until the heater and installation is passed as safe. If the pilot continues to be extinguished, you must call your installer to check the operation of the complete heater.

CLEANING

Ensure that the heater is turned off before cleaning and is cold. Glass panels can be cleaned with a suitable glass cleaner. Test on a small area first.

DO NOT use abrasive cleaning agents.

SERVICING

It is essential that the heater is regularly serviced at, least annually.

The heater must only be fitted with the vermiculite supplied. DO NOT use ant extra logs or coals.

GUARANTEE

CONDITIONS OF GUARANTEE

Your ESSE is guaranteed against defects arising from faulty manufacture for 2 years when supplied by an ESSE Specialist.

Upon registration of the warranty, ESSE will extend the guarantee period to 5 years from purchase. Your details must be registered with us by either returning the completed warranty card or by completing registration on-line at www.esse.com. The warranty must be registered within 1 month of installation to qualify for the 5 year warranty.

The appliance must be only used for normal domestic purposes and in accordance with our instructions, be correctly installed and serviced.

The guarantee does not cover:

Installation

Wear and tear

Parts deemed to be replaceable or service parts including electrical components that may be replaced during the normal usage of the appliance.

This guarantee is personal to the original purchaser and not transferable.

Any stove or defective part replaced shall become the Company's property

HOW TO PROCEED WITH A COMPLAINT

If you have cause for dissatisfaction with your stove, you should first contact your ESSE dealer, who will bring your concerns to our attention. We will assess the nature of the complaint and either send replacement parts for your dealer to fit, or arrange for an ESSE engineer to inspect the appliance and carry out any work that may be deemed necessary. If the fault is not actually due to faulty manufacture but some other cause i.e. misuse, failure to install correctly, or failure to service at regular intervals, a charge will be made to cover the cost of the visit and any new parts required.

SPARE PARTS

Only genuine ESSE spare parts are recommended.



ESSE Engineering Limited, Ouzledale Foundry, Long Ing, Barnoldswick, Lancashire

BB18 6BJ

Tel. 01282 813 235, **Fax:** 01282 816 876

Website and On-line Store <http://www.esse.com>

Page 36

41L48L-I01-270318