

ESSE

1000 T
Heat Storage Range Cooker

Instruction Manual

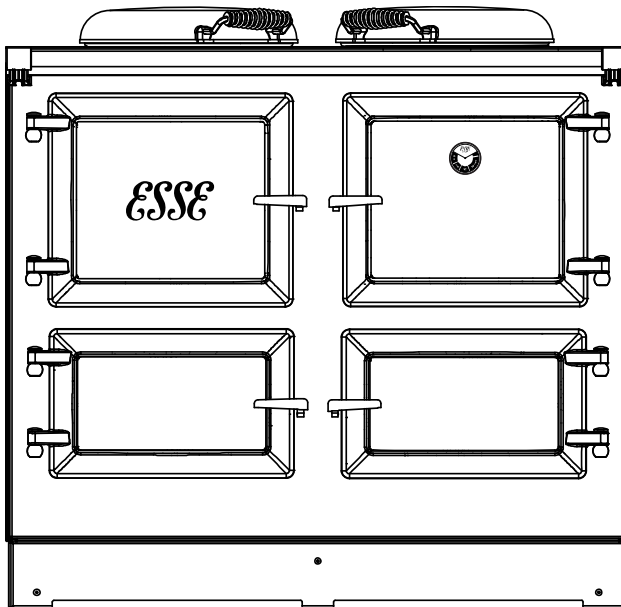



















CONTENTS

1. GENERAL HEALTH & SAFETY	3
2. WELCOME TO YOUR ESSE	4
3. PRODUCT OVERVIEW AND QUICKSTART GUIDE	5
UNPACKING THE APPLIANCE	5
SWITCHING THE COOKER ON FOR THE FIRST TIME	6
4. OPERATING INSTRUCTIONS	7
THE CONTROLS	7
LOW ENERGY MODE	7
THE CLOCK AND TIMER.....	8
LOW ENERGY MODE USING TIMER PROGRAM	8
THE DOORS	12
INSIDE DOOR LINERS	13
THE OVENS.....	14
THE STEAM VENTS	15
THE GRILL.....	16
THE HOTPLATE	18
HEAT UP TIMES.....	18
THE INDUCTION HOB.....	19
ESSE ACCESSORIES AND COOKWARE	22
CLEANING & MAINTENANCE	23
WARRANTY	24
TROUBLESHOOTING	25
5. INSTALLATION INSTRUCTIONS	26
PLANNING THE INSTALLATION	26
REQUIRED SPACE	26
POWER SUPPLY.....	28
PRODUCT SPECIFICATION	28
VENTILATION	28

1. GENERAL HEALTH & SAFETY

All ESSE heat storage range cookers are designed and manufactured to be simple and efficient to use, and we've taken great care to ensure that they meet the applicable safety requirements, when appropriately installed and used. Before use, ensure you are familiar with the following:

	The appliance can be used by children aged from 8 years and above and persons with reduced physical, sensory or mental capabilities or lack of experience and knowledge if they have been given supervision or instruction concerning use of the appliance in a safe way and understand the hazards involved.
	Children should not play with the appliance. Cleaning and user maintenance MUST not be made by children without supervision.
	WARNING: Accessible parts may become hot during use. Young children should be kept away from the appliance.
	The appliance must be installed on a level surface, capable of taking the weight of the cooker. If installing on a base, the appliance must not be able to slip off the base.
	WARNING: The appliance and its accessible parts become hot during use. Care should be taken to avoid touching heating elements inside the ovens.
	WARNING: Unattended cooking on a hob with fat or oil can be dangerous and may result in a fire.
	WARNING: Danger of fire. Do not store items on the cooking surfaces.
	CAUTION: The cooking process has to be supervised. A short term cooking process has to be supervised continuously.
	Ensure that the kitchen is well ventilated. Natural ventilation holes within the room must be left open, or install a mechanical ventilation device, such as an extractor hood.
	WARNING: If the Induction hob glass is cracked, the cooker should be switched off and isolated from the power supply, to avoid possibility of electric shock.
	Metallic objects such as cutlery, cooking utensils and pan lids should not be placed on the hob surface, as they may become hot.
	WARNING: Any spillages on the bolster lids should be removed before they are opened.
	WARNING: Do not use a steam cleaner to clean any part of this appliance.
	The appliance must be installed in such a way that allows for disconnection from the power supply after installation.
	CAUTION: This appliance is not intended to be operated by means of an external timer or separate remote-control.
	If any of the supply cords are damaged, it must be replaced by the manufacturer, its service agent or similarly qualified persons in order to avoid a hazard.
	NEVER try to extinguish a fire with water, but switch off the appliance and then cover flame e.g. with a lid or a fire blanket.
	The appliance must not be placed behind a decorative door, so as to avoid overheating.

2. WELCOME TO YOUR ESSE

Welcome to the ESSE family. All ESSE cookers are manufactured at our factory in Barnoldswick, Lancashire, and we're confident that if appropriately installed, maintained and cared for, your ESSE will provide you with many years of cooking, baking, heating, drying and general comfort and joy.

Before you switch on your ESSE for the first time, ensure that your installer has installed the cooker in line with the 'Installation' section of this manual, and that the protective plastic film has been removed from the inside face of the four doors.

This appliance is designed for domestic cooking and heating only. Use for any other purpose could invalidate the warranty.

These instructions provide all the necessary information to both install, then operate your ESSE, so please retain them for reference. The key information relating to your ESSE, including the serial number, can be found on the data plate, located on the inside face of the top left door. Please quote the model and serial number, in any future communication with your retailer or the manufacturer.

At ESSE, we work hard to continuously look for ways to improve our products, and as such, we reserve the right to change specifications and make modifications to the appliance described within this manual, at any time.

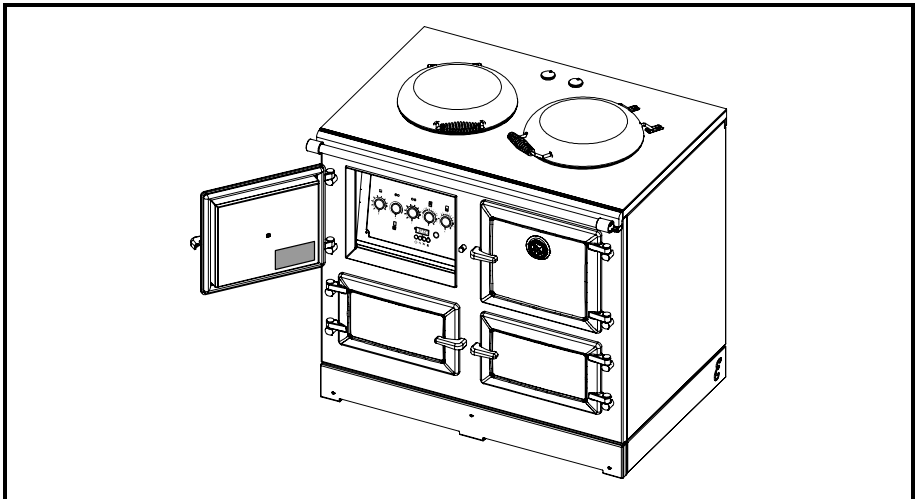

Data plate location

3. PRODUCT OVERVIEW AND QUICKSTART GUIDE

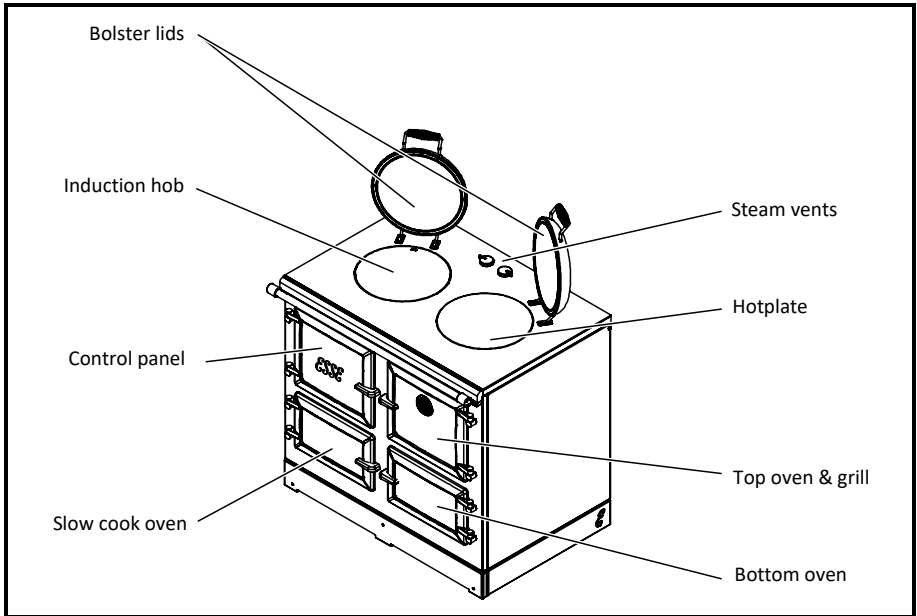

Key features and parts

INCLUDED WITH YOUR ESSE	
✓ Oven Shelves (X4)	✓ Oven Glove and Apron
✓ Grill Pan	✓ Wire Brush
✓ Roasting Dish	✓ Instruction Manual

UNPACKING THE APPLIANCE

To unpack your ESSE cooker, first remove all of the outer packing. Next, locate the supplied accessories from the top and bottom ovens, and move to one side. Remove the protective film on the inner door liners.

At this time please examine the cooker for any damage to the surface finishes and glass hob. In the unlikely event of any damage being observed on your ESSE cooker, or should any of the supplied accessories be missing, please contact your retailer for advice.

Finally, dispose of the remaining packaging responsibly.

	Ensure the protective plastic film covering the inner door liners is removed before switching the appliance on – Failure to do so may result in damage to the cooker.
--	---

SWITCHING THE COOKER ON FOR THE FIRST TIME



Ensure that the control dials are in the 'off position', before connecting the appliance to the power source.

Once the power supply is connected, you will hear a beep from the induction hob, and the cooling fan will temporarily activate, before switching itself off. The inbuilt clock will initially show 'ESSE', before defaulting to '12.00'. The instructions to set the clock can then be followed, as shown in the Operating Instructions section of this manual.

4. OPERATING INSTRUCTIONS

THE CONTROLS

The controls for the ovens, hotplates and grill are located behind the top left door.

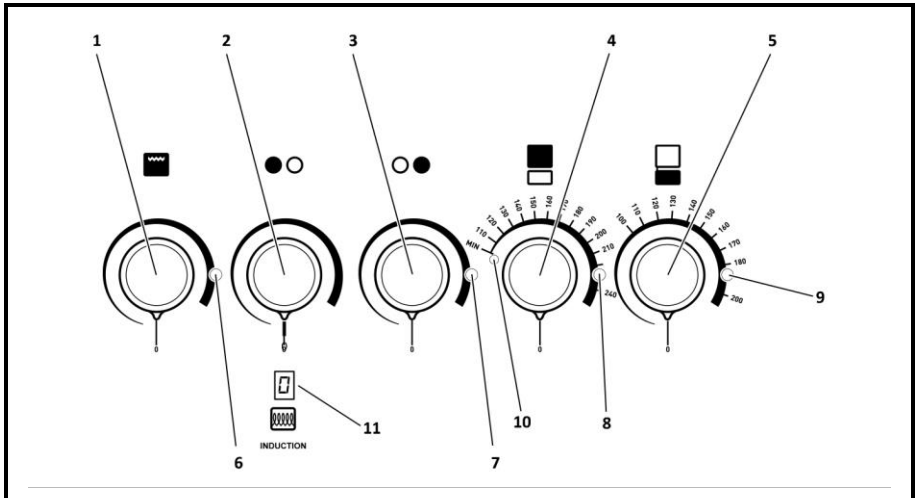

Controls overview

1	Grill temperature dial
2	Induction hob temperature dial
3	Hotplate temperature dial
4	Top oven temperature dial
5	Bottom oven temperature dial
6	Grill indicator light

7	Hotplate indicator light
8	Top oven indicator light
9	Bottom oven indicator light
10	Top oven setting 'MIN'
11	Induction setting display

The top oven, bottom oven, grill, hotplate and induction hob are controlled by simply rotating the appropriate dial. When the dial is rotated clockwise, the relevant indicator light will switch on, to indicate that it is in use.

LOW ENERGY MODE

ESSE heat storage range cookers are designed to be permanently left on. The top oven must be set at 'MIN' which will allow the cooker to heat up to cooking temperature more quickly, whilst managing power consumption and running costs. Keeping your ESSE switched on will also allow you to enjoy all the benefits which an ambient heat source brings.

To activate the top oven on initial start-up, use a flat ended tool, depress the black button and move the dial over the button to 'MIN'.

4. OPERATING INSTRUCTIONS

THE CLOCK AND TIMER

The clock and timer allows for the temperatures of the top oven, bottom oven and cast iron hotplate to either be adjusted manually, or to rise from slumber to any pre-selected temperature, at a chosen time of day.

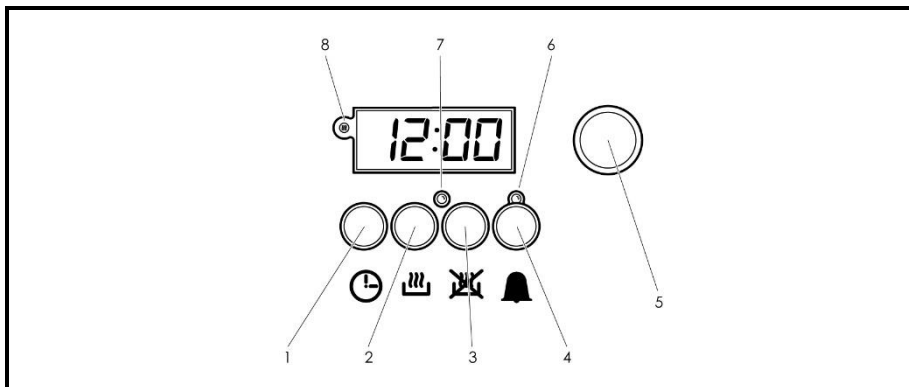

Timer controls

1	Clock Set Button
2	On Time Button
3	Off Time Button
4	Countdown Timer Button

5	Control Dial
6	Countdown Timer LED
7	Manual Operation LED
8	Light Sensor

Setting the clock

To set the clock...

1. Push and hold down the 'Clock Set' button (1), and rotate the 'Control Dial' (5) until the correct time is reached.
2. Release the 'Clock Set' button.

Your ESSE is factory set for the temperature of the hotplate and two main ovens to be controlled manually, using the four temperature control dials hidden behind the top left door. When the Manual Operation LED (7) glows orange, your ESSE is set to 'Manual Control'.

LOW ENERGY MODE USING TIMER PROGRAM

Using the timer, it is possible to programme the hotplate and two main ovens, to any desired temperature at a selected time of day. For example, you could programme the top right oven to heat up from 'MIN' to 180°C at 6.30pm, then back down to 'MIN' at 8.30pm. This means that you do not have to remember to manually raise the oven temperature, in advance of cooking. After the program is finished the top oven will revert to 'MIN', warming oven to 75°C and all other cooking areas to '0'.

4. OPERATING INSTRUCTIONS

NOTE: The timer incorporates a light sensor, (8), which reduces the brightness of the LCD time display when there is low light, (ie, when the door is closed), so as to reduce power consumption and prolong the lifetime of the timer.

Using the timer

By programming the timer, the top oven will be automatically placed to 'MIN' with the warming oven at 75°C and the hotplate and lower right oven to '0'. Your ESSE will then automatically increase the temperature of the hotplate / oven(s), to the desired temperature, at the desired time of day.

To programme the timer...

1. Set the hotplate / oven(s) to the desired temperature, using the temperature control dials.
2. Set the hotplate / oven(s) desired 'On' time...
 - Push and hold down the 'On Time' button (2).
 - Rotate the 'Control Dial' (5) until the desired time is reached*.
 - Release the 'On Time' button (2), to store the time.
3. Set the hotplate / oven(s) off time...
 - Push and hold down the 'Off Time' button (3).
 - Rotate the 'Control Dial' (5) until the desired time is reached.
 - Release the 'Off Time' button (3), to store the time.
4. Store the program...
 - Push and hold down both the 'On Time' (2) and 'Off Time' (3) buttons simultaneously.
 - The screen will flash 'OFF', to show that manual operation has been switched off, and that a timer program is active.
 - The four red LEDs will bounce on / off along the line of the temperature control dials, and the 'Manual Operation LED' (7) will turn off, to indicate that the hotplate / oven(s) are in energy saving mode.

When the selected 'off' time is reached, the orange 'Manual Operation LED' (7) will turn off and the hotplate and bottom oven will start cooling back down to '0' and the top oven to 'MIN'.

**Remember to factor in at least 30 minutes to your 'On Time' to heat up, before the time you want to start cooking.*

You may want to temporarily override the heat up timer, to manually move the hotplate / oven(s) to a cooking temperature, (before the 'On Time' time is reached), or to cool them from the set temperature, (before the 'Off Time' time is reached). This is easily done by pressing buttons '2' and '3' together on the timer, then reset the controls manually to the desired temperatures.

4. OPERATING INSTRUCTIONS

Overriding the timer By pressing buttons '2' and '3' together the indicator light (7) will be illuminated and you will have manual control of all cooking zones. Your pre-set timer program will resume automatically after 24 hours.

Deactivating the timer (returning to manual operation) To cancel the timer programming and return to manual operation, simply re-programme the timer module, with the 'On Time' and 'Off Time' times set to the same time, eg, 12.00 for both.

1. Set the hotplate / oven(s) on time to a notional time, eg, 12.00.
 - Push and hold down the 'Time On' button (2).
 - Rotate the 'Control Dial' (5) until 12.00 is reached.
 - Release the 'Time On' button, to store the time.
2. Set the hotplate / oven(s) off time to the same notional time, ie, 12.00.
 - Push and hold down the 'Time Off' button (3).
 - Rotate the 'Control Dial' (5) until 12.00 is reached.
 - Release the 'Time Off' button, to store the time.

Your ESSE is now in manual operation, so remember to adjust the temperature control dials to '0', low energy mode or any other desired temperature.

The timer incorporates a countdown alarm, which can be set to count down any period of time. Once the set time period has elapsed, the timer will beep until switched off.

4. OPERATING INSTRUCTIONS

Countdown alarm

To set the countdown timer...

1. Push and hold down the 'Countdown Timer' button (4).
2. Rotate the 'Control Dial' (5) until the desired time value is reached (hours and minutes).
3. Release the 'Countdown Timer' button (4).
4. The orange 'Countdown Timer LED' (6) will turn on, indicating that the countdown timer is active.
5. When the time period has elapsed, the timer module will beep.
6. To cancel the beeping, press the 'Countdown Timer' button (4) once.
7. The orange 'Countdown Timer LED' (6) will turn off.

To cancel the countdown timer, mid-programme, set the time value to 00:00.

PLEASE NOTE – The countdown timer does not affect the temperature of the hotplate / ovens – it is purely an alarm.

4. OPERATING INSTRUCTIONS

THE DOORS

The four cast iron doors are opened by lifting the chrome catch upwards, then swinging the door forwards. Take care not to allow the door to swing open freely and clash with adjacent cabinets / surfaces.

To close the doors, carefully but firmly push the door back into position, until the door catch engages and holds the door shut.

Adjusting the door catches

Over time, the door catches may need adjusting. This is typically a result of the rope seals flattening, (and the doors becoming a little loose), or the cast iron doors expanding naturally over time, (and becoming a little tight).

To adjust a door catch...

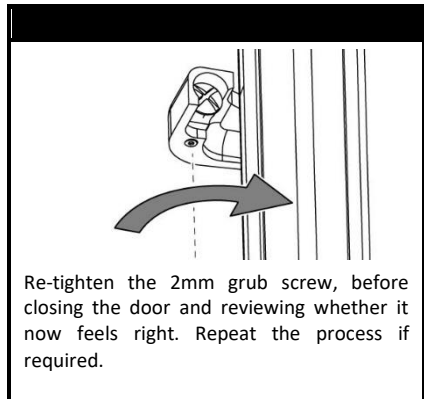
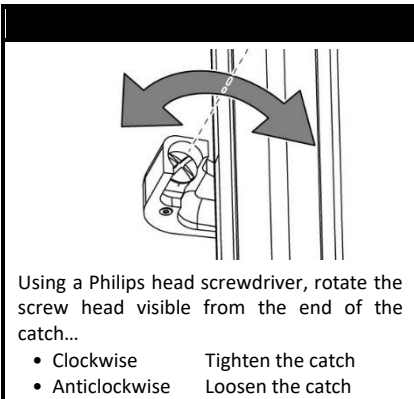
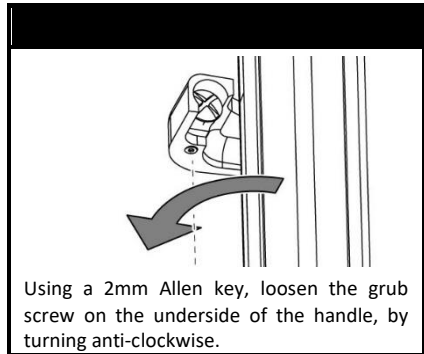
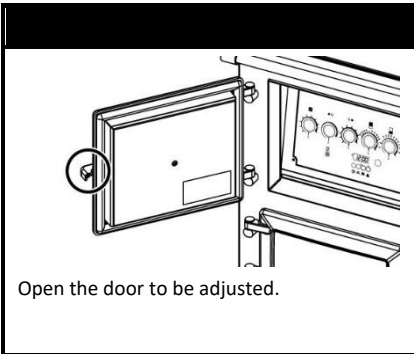

4. OPERATING INSTRUCTIONS

INSIDE DOOR LINERS

The door liners can be removed from the inside of the doors for cleaning. To remove the door liners...

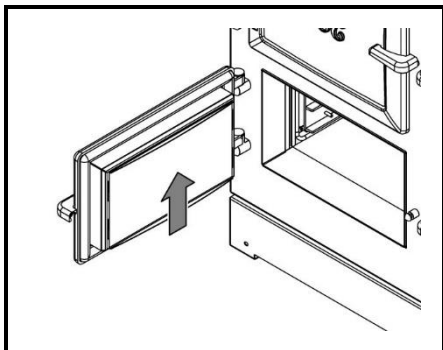

1. Use the door liner handles to lift upwards

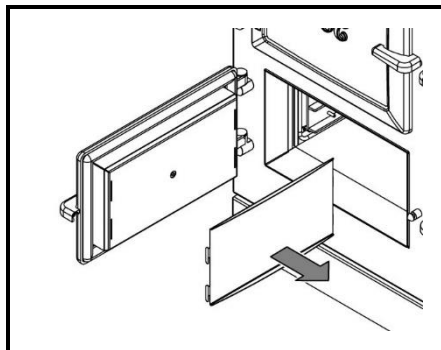

2. Pull the door liner clear of the door

To replace the door liners, repeat the above process in reverse.

4. OPERATING INSTRUCTIONS

THE OVENS

Your 1000 T incorporates three cooking ovens, all of which incorporate ESSE's patented wrap around elements. The heating elements provide a unique even heat source from front to back and top to bottom, so there's no need to rotate oven trays, or adjust shelf heights. As a result, during cooking the bottom of each oven can also be used to place oven trays on to.

- | | |
|-----------------------|---|
| Top oven | <ul style="list-style-type: none">• Variable temperature control up to 240°C.• Incorporates the grill, with a dedicated control. |
| Bottom oven | <ul style="list-style-type: none">• Variable temperature control up to 200°C. |
| Slow cook oven | <ul style="list-style-type: none">• Fixed temperature of around 75°C, ideal for slow cooking or plate warming.* |

Oven shelves The oven shelves are designed to slide in and out of the ovens. They incorporate a feature to prevent them from sliding forward and out of the oven unintentionally.

To insert the shelves, offer the shelf up to the oven at a 45° angle, resting the angled end of the wire shelf on the desired runner within the oven, and gently push it forwards. Once the angled end has passed under the metal pins on the side walls of the oven, swing the wire shelf down until it is horizontal, then push it forward all the way into the oven.

To remove the shelf, repeat the process in reverse.

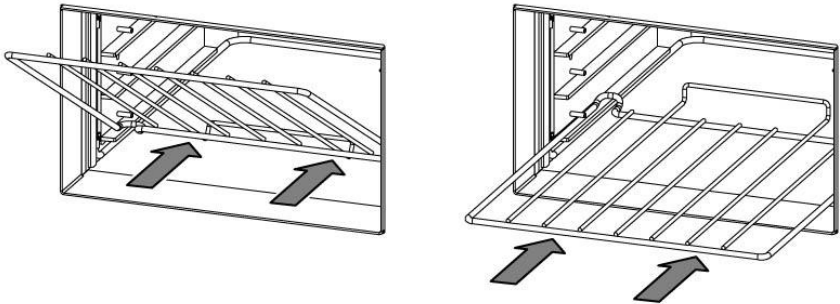

*To achieve and maintain 75°C in the slow cook oven, the top oven must be left on 'MIN' allowing all of the cooker to fully heat up.



The oven shelves will be hot when the oven is in use, and for a time afterwards. Always use an oven glove when adjusting their position.

4. OPERATING INSTRUCTIONS

Temperature gauge Your ESSE incorporates a temperature gauge within the large oven door. This can be used to provide an indication of the oven temperature, but due to how the oven is heated, should not be relied upon to give an exact temperature reading.

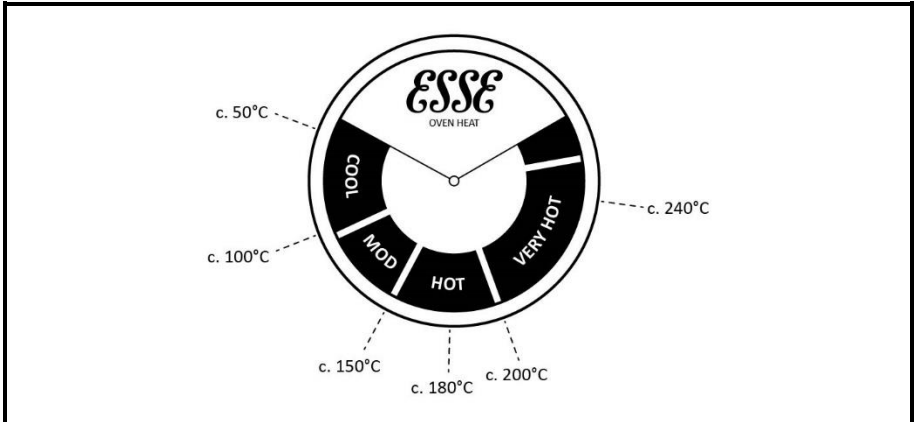

The Oven Gauge, with temperature guide

THE STEAM VENTS

All cookers produce steam when in use. Your ESSE incorporates two 'steam vents' located at the rear of the top surface. The steam vents can be adjusted to either retain or release the steam, depending upon what you are cooking in the ovens.

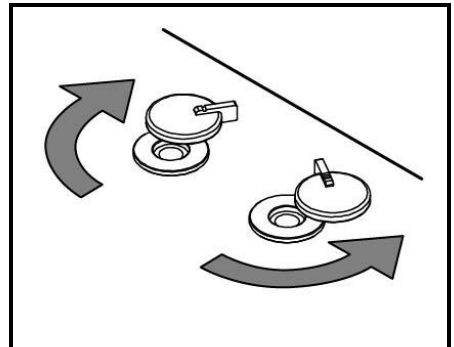
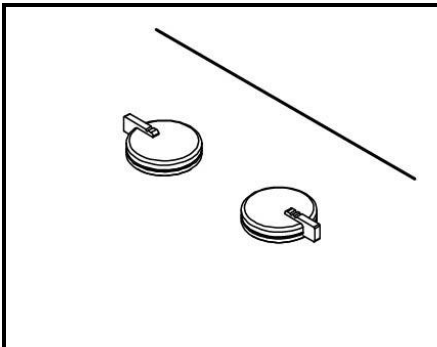

Opening and closing the steam vents

4. OPERATING INSTRUCTIONS

For example...

Steam vent closed If you are cooking something which will benefit from retaining the moisture, (such as baking a sponge cake), the steam vent can be left closed, to keep the moisture within the oven.

Steam vent open If you are cooking something which would benefit from the moisture escaping, (such as roast potatoes), the steam vents can be swung open, to allow the moisture to escape.

For certain items, (such as when roasting a joint or poultry), it may make sense to have the steam vents closed throughout the majority of the cooking time, before opening it towards the end, to crisp up the outside.

The Steam Vents are marked to indicate which oven they are linked to...

I Top oven

II Bottom oven



The steam vents can become hot during use, so always wear the supplied glove when adjusting them, to open or close.

THE GRILL



The door **must** be left fully open when using the grill.

The grill is located within the top oven. When in use, the grill overrides the oven, so the top oven elements will switch off when the grill is turned on. (The two bottom ovens and hotplate remain unaffected by the grill being in use). If the top oven was in use when the grill was switched on, the oven will switch back on automatically, once the grill is switched off.

The grill is switched on by rotating the control dial clockwise, and the power level set as appropriate. The grill indicator light glows red when the grill is switched on, to indicate it is in use. For best results, allow 4 – 5 minutes for the grill to heat up to temperature before starting to use it, when it is heated up from cold.

As a safety feature, the grill is programmed to be active for a maximum of 30 minutes, and will switch off automatically after this time period. If you wish to continue to use the grill, you must manually turned the dial back to the 'Off' position, and then turn it back to the desired setting.

4. OPERATING INSTRUCTIONS

The supplied grill pan should be positioned on a wire shelf, which can be fitted on any of the four heights of oven shelf runners. Typically the top shelf runner is used for grilling, but take care to ensure that the food to be grilled does not touch the grill element.

We recommend positioning the wire shelf in the correct position, before switching on the grill.

Grill pan

The supplied grill pan comes in three parts – the pan, the wire rack and the handle. The wire rack simply drops in place into the pan. To fit the handle, first drop the wire hook over the inside of the pan, then slide it to the centre, to lock in position.

We recommend removing the handle whilst grilling, so it does not get too hot.

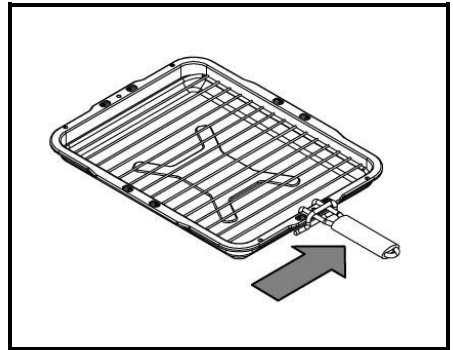
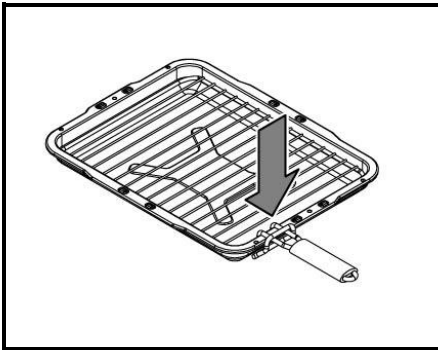

Assembling the grill pan



The towel rail may become hot when the grill has been used for a prolonged period. Do not place towels or similar items on the towel rail during or immediately after grilling.

4. OPERATING INSTRUCTIONS

THE HOTPLATE



For your peace of mind, we fully test your ESSE cooker in our factory before it leaves us, so as a result, you may see some slight discolouration of the hotplate.

The hotplate can be used completely independently from the ovens, and the temperature can be fully adjusted with the control dial. As with the ovens, we have suggested a position on the control dial for slumber, but you can adjust this to suit your needs.

When set to maximum, the hotplate surface will reach temperatures of close to 350°C.

The bolster lid should be closed whilst the hotplate is heating up, to reduce the time taken to reach the desired temperature. However, whilst the bolster lid is insulated, the top chrome face does still get warm when the hotplate is in use, so care should be taken.

We strongly advise against placing any cookware, (including pans, casserole dishes, kettles, etc.), directly onto the bolster lid surface, as this can cause irreparable scratches on the chrome finish. You may want to invest in some round hob lid covers, which will protect the top surface of the bolster lids. These are available through your retailer, or at www.esse.com.



Any spillages on the hotplate should be cleaned up immediately with a damp cloth.

HEAT UP TIMES

Your 1000 T is designed to be permanently left on, ensuring the cooker is ready to provide the unique surround heat for perfect cooking and baking, provided by an ESSE. Keeping the top oven at 'MIN' will dramatically reduce the heat up time of the oven and prevent a build-up of moisture, (which can lead to rusting), whilst also providing a gentle warmth to your kitchen.

Power Share Technology

ESSE heat storage range cookers incorporate unique technology which shares power between the active elements on a cycle. This both reduces the heat up time of the cooker, whilst also providing favourable power consumption and running costs. The 3kW rating of the cooker is cycled between the active elements, ensuring each element receives the full 3kW of power. However, as a result, the more elements which are active, the longer it will take to initially heat them up to temperature.

The heat up times for your ESSE vary, depending upon how many elements are active, whether they are heating up from cold or slumber, the desired cooking temperature, along with the ambient temperature of your kitchen. However, as an approximate indication, from cold the hotplate takes in the region of 25 – 30 minutes to heat up to cooking temperature, whilst the ovens take in the region of 45 – 60 minutes.

4. OPERATING INSTRUCTIONS

THE INDUCTION HOB

The induction hob can be used completely independently from the ovens, and the temperature can be fully adjusted with the control dial. The induction setting display indicates what setting the induction hob is set to. Up to three pans can be used on the large induction hob, as indicated in the pan placement section of this document.

Using pans on the induction hob

To get the best out of your induction hob, it's crucial to only use the correct material, size and shape of pans.

The correct material

Due to the way induction hob technology works, it is critical that only pans of the correct material are used. Typically, cookware made from cast iron, stainless steel and composite (which incorporate a thick steel section within the base), are appropriate for use on your induction hob. Appropriate pans stick to magnets, so as a quick and simple check, offer a magnet up to the base of the pan – if the magnet has a strong attraction, the pan is appropriate.

Pan sizes

Up to three pans can be used on the induction hob. However, the minimum appropriate size of pan is 145mm diameter. Using a pan or cookware of a smaller size may damage your induction hob.

Pan bases

To be most efficient, the base of the pan should be completely flat, and not be curved upwards or downwards, or have ridges in it. In extreme cases, pan surfaces that are not flat may not work at all on the induction hob.



When using cast iron pans, we recommend only using cookware with a base that is treated, with a smooth enamel finish, or that has been ground flat. Untreated cast iron, with a rough surface may scratch the glass top of your induction hob.

When in use, the induction zone will generate a faint, repeating ticking noise. This is perfectly normal and does not indicate that the pan is not appropriate to use.



We strongly recommend lifting pans off the induction zone and hob, rather than sliding them, so as to not scratch or damage the glass induction top.

4. OPERATING INSTRUCTIONS

Using the induction hob

Pan detection

The induction hob has a built in pan detection system, which only supplies power to the induction zone, if an appropriate pan has been detected.



If no appropriate pan has been detected, a flashing 'U' will be shown in the induction zone control, indicating that no power is being supplied to the induction zone.

This feature automatically cuts power to the induction zone when a pan is temporarily removed from the hob.



After use, switch off the induction zone by its control - do not rely upon the pan detector to cut power.

Power boost

When cooking on an induction zone, typically one of the power settings from 1 – 9 is appropriate to give the desired intensity of heat. However, when bringing a pan to the boil, the power boost function can be used. This function is indicated by a 'P' displayed within the zone display, and can be found by gently rotating the induction hob dial clockwise, when set to 9.



This function will continue for a maximum of 5 minutes, after which the setting will automatically drop down to '9'.



When using the power boost function, take care that the pan does not boil over, particularly when covering the contents with a lid.

4. OPERATING INSTRUCTIONS

Automatic heat up

To quickly achieve cooking temperature, the automatic heat up feature turns the induction to the power boost setting for a short period of time, until the desired temperature is reached. At which point, the induction hob automatically re-sets to the chosen power setting.

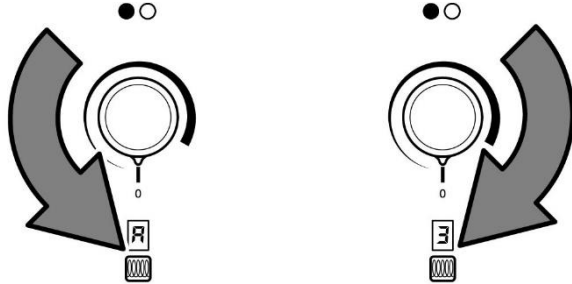

To activate the automatic heat up feature...

1. Place an appropriate pan on the induction hob.
2. Gently rotate the induction hob control dial anticlockwise, holding it in position for 2 seconds, until you hear a beep, and the induction hob display shows 'A'.
3. Then rotate the induction hob control dial clockwise, until you reach the desired power setting. The induction hob display will now alternate between showing 'A' and the chosen power setting.
4. Once the pan has reached the chosen temperature, the induction hob will re-set to the chosen power setting, which will be shown in the induction hob display.

Residual Heat Display



The technology used within your induction hob means the pan is heated directly, and not the glass. However, the hot pan transfers heat back down to the glass during use, leaving residual heat within the glass, even when the pan has been removed.

To highlight this, the zone display will show 'H' for a short time after use, to indicate that the glass remains hot.

4. OPERATING INSTRUCTIONS

Pan Placement

Up to three pans can be used on your induction hob. However, it is important to ensure that the pans do not touch in two or more places, when placed on the active induction hob. Doing so will create an extended induction field, which may cause permanent damage to your pans.

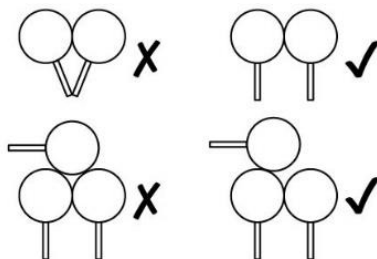

Cooling fan

A cooling fan will switch on at times during use of the induction hob, to circulate air around the electronics. This is to help maximise the life and efficiency of your induction hob. After switching off the induction hob, the cooling fan should switch off within a few seconds.

ESSE ACCESSORIES AND COOKWARE

Your 1000 T came supplied with an ESSE Roasting Dish, Grill Pan, Oven Glove and Apron. However, additional ESSE cookware is available to purchase, through our cookware website at www.esse.com/cookware

Our cookware range includes great items for use with your ESSE, including a Cast Iron Casserole Dish, Cast Iron Griddle Pan, Stainless Steel Kettle and Bolster Lid Covers.

4. OPERATING INSTRUCTIONS

CLEANING & MAINTENANCE

Your ESSE heat storage range cooker should be inspected frequently, and any required maintenance undertaken.



Take care of hot surfaces when cleaning the appliance. We recommend only cleaning the appliance when it has been switched off.



Do not use abrasive pads, caustic cleaners, oven cleaners or aggressive cleaning chemicals to clean the coated doors, front, top or side panels, or the chrome bolster lids & towel rail.

General cleaning

In general, most of your ESSE can be kept clean using a soft lint-free cloth and soapy water, and then immediately drying with a dry cloth. We recommend any liquid or food spills are cleaned up immediately, so as not to bake onto the cooker, or discolour the surface material.

We recommend giving the front, doors and top a wipe down daily, or after use.

Bolster Lids

The exterior chrome finish should be cleaned with a lint-free cloth, using soapy water, and immediately dried with a dry cloth, to prevent smearing. To keep the chrome shiny, use specialist chrome cleaning products. Do not use a scouring pad, as this will scratch the surface.

The inside face should be cleaned with a lint-free cloth, using soapy water, and immediately dried with a dry cloth. Do not use a scouring pad, as this will scratch the surface.

Cooker front, doors and side panels

We recommend daily wiping down with a lint-free cloth, using soapy water, and immediately dried with a dry cloth, to prevent smearing. Any condensation moisture should be dried with a dry cloth, so as not to create smearing.

Top surface

For general cleaning, we recommend using a soft lint-free cloth and soapy water, and then immediately drying with a dry cloth. Liquid or food spills should be cleaned up immediately, so as not to bake onto the cooker, or discolour the surface material.

Hotplate

Liquid or food spills should be cleaned up immediately, (whilst taking care to avoid direct contact with the hot parts), so as not to bake onto the cooker. Stubborn stains can be removed with an appropriate cleaning pad, such as a Scotch-Brite™ Hand Pad (Maroon).

Induction hob

Liquid or food spills should be cleaned up immediately, (whilst taking care to avoid direct contact with the hot parts), so as not to bake onto the cooker. Stubborn stains can be removed with an appropriate specialist hob cleaner, such as Hob Brite. DO NOT use Hob Brite, or similar cleaning products on the coated doors, front, top or side panels, or the chrome bolster lids & towel rail.

4. OPERATING INSTRUCTIONS

- Ovens** Do not use an oven cleaner on the ovens. Instead, wipe down with a soft lint-free cloth and soapy water, and then immediately dry with a cloth. The ovens should be switched on after cleaning, to ensure that they are dry. Stubborn stains can be removed with the supplied wire brush. To season and help protect the ovens, a fine layer of flax oil can be applied to the inside of the ovens.
- Inside door covers** The inside stainless steel door covers should be cleaned with a lint-free cloth, using soapy water, and immediately dried with a dry cloth.
- Stubborn stains can be removed with a soap impregnated pad or specialist stainless steel cleaning pad, such as a Scotch-Brite™ Hand Pad (Maroon). Using aggressive cleaning pads will result in additional hairline texture in the metalwork, but it is down to the individual user to decide if this is preferable to stained inside door covers.
- Roasting dish** The supplied roasting dish is enamelled coated, so should be washed in warm soapy water. A gentle scouring pad can be used if required. Dishwashing of the dish is possible, but over time, will result in a dimming of the shiny finish.
- Rope seals** Over time, the rope seals on the doors will soften, and may need replacing. Replacement rope and bonding silicone are available through your retailer, or online at www.esse.com



Repairs or modifications should only be undertaken by ESSE authorised professionals. Only genuine ESSE replacement parts should be used, or your warranty may become invalid.

WARRANTY

Your ESSE heat storage range cooker has been built to the highest standard using premium materials, and comes with a two year manufacturer's warranty. Register your ESSE online at www.esse.com/warranty-registration.

The conditions of your warranty are...

- X Does not cover incorrect use or application, as advised within this manual.
- X It must be installed appropriately.
- X Does not cover rope door seals.
- X Does not cover general wear and tear or cosmetic damage unrelated to the function of the appliance.

4. OPERATING INSTRUCTIONS

TROUBLESHOOTING

Problem	Cause	Solution
Grill not working effectively	• The grill has not been switched on.	• Ensure the grill dial is turned clockwise to the desired setting, and the indicator light is glowing red.
	• The grill is set to automatically switch off after 30 minutes of use.	• Manually switch the grill off, then back to the desired setting.
	• The grill pan is positioned too low in the oven.	• Switch the grill off, then using an oven glove, reposition the wire shelf closer to the grill.
Condensation	• The oven, hotplate or grill is heating the cold metal of the cooker, and causing condensation.	• Wipe the condensation up with a clean cloth, ensuring it is dry, to avoid smearing.
		• Leave top oven at 'MIN' when the cooker is not in use.
		• Open the relevant steam vent, to allow excess moisture to escape.
	If switched off for a prolonged period leave the oven doors ajar and bolster lids open.	
Control LED flashing red and green alternatively	• Thermocouple fault.	• Call your retailer for support.
Induction zone not working	• Induction hob is not switched on.	• Switch the hob on using the Power On / Off button.
	• Pan is not an appropriate material.	• Use a pan of appropriate material.
	• Pan base not flat.	• Use a pan with a flat base.
Oven or hotplate not working / getting to temperature	• Not switched on.	• Switch on using the appropriate dial on the controls.
	• Timer is on, with the temperature set at slumber	• Either remove the timer programme and switch on 'Manual Operation', or temporarily override the timer programme.
	• Thermocouple fault.	• Check if an LED is alternating green and red – if so, call your retailer for support.
Solid red lights across the control panel	• Power cut.	• Turn all dials to '0'. Turn off and on at plug socket and revert to start up guide on page 7.

5. INSTALLATION INSTRUCTIONS

PLANNING THE INSTALLATION

It is the installer's responsibility to ensure that when installing the appliance, the requirements of the Health and Safety at Work Act 1974 are met.

The installation instructions within this manual provide a guide for safe and appropriate installation, but it is the responsibility of the installer to ensure that the requirements of applicable British Standards are met.

It is the responsibility of the customer to ensure that the appliance is installed appropriately, and that the electrical installation conforms to local and national regulations, engaging with a qualified electrician as required.

Ensure that the mains supply corresponds to that of the appliance, which can be found on the inside face of the door covering the controls.



WARNING : This appliance must be earthed.

Whilst not a legal requirement, we recommend the inclusion of an individual Residual Current Device (RCD) to the cooker supply circuit.



WARNING : During installation, there is an electric shock hazard.

We do not recommend using extension cables with this appliance.

REQUIRED SPACE

To best receive your new ESSE, we strongly recommend that you take care to ensure that the space is properly prepared.

ESSE heat storage range cookers are hand crafted, so small variations in size can occur.

Space requirements Your ESSE 1000 T is 985mm wide, 900mm high (from floor to the top of the work surface), and 640 mm deep (from the front face, to the rear surface).

However, with the bolster lid up, your ESSE is 600mm taller, so make sure nothing above stops the lids from opening – We recommend a height of 1,375mm, (to include handle access).

Ensure that the floor is flat and level, (use a spirit level), and appropriate for the weight of your ESSE – approximately 300kg.

Your ESSE should be installed with 3mm gap either side, to non-combustible surfaces, (such as a brick wall).

5. INSTALLATION INSTRUCTIONS

However, if your ESSE will be positioned next to a combustible surface, (such as an unprotected solid wood work surface), we strongly recommend you increase this distance to 20mm, to reduce the risk of the worktop cracking.

Ensure that there is a minimum 10mm gap between the rear of the cooker and the back wall / vertical surface – This is to help with air circulation to the induction hob.

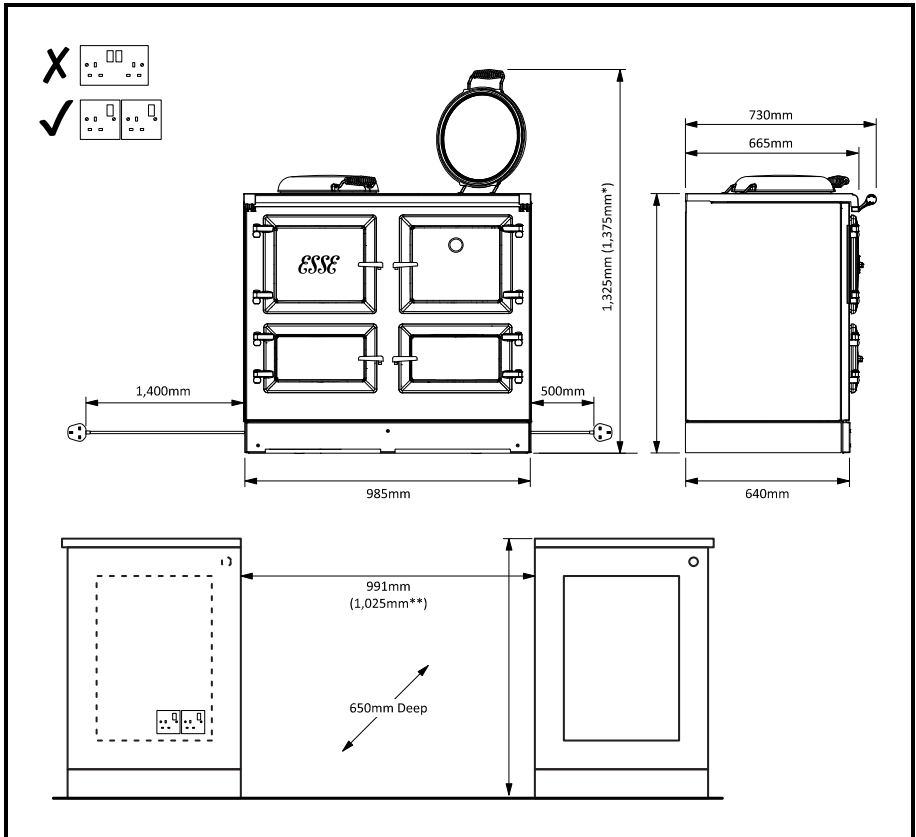

* Leave space to grasp the handle ** When positioned next to wood worktops.

5. INSTALLATION INSTRUCTIONS

POWER SUPPLY

Your ESSE 1000 T is simple and easy to install, with two 13 Amp plugs. As a result, your ESSE can simply be plugged in to two standard 13A plug sockets.

13 Amp model

We strongly recommend using two individual sockets, rather than a 'double socket' – It is best practice for any electrical item in constant use, to have a dedicated single socket for each plug, so as to remove the remote risk of electrical wiring within the socket overheating.

The sockets should be positioned to the side of your ESSE, not behind it, (as the additional depth will require your ESSE to be positioned further forward) – Preferably, have the sockets to the left of your 1000 T, which is closer to the mains cable port on your ESSE.

You may want to hide the two sockets within a cupboard, with a 60mm hole drilled at the bottom right hand side, to feed the two plugs through.

The mains cable length is 1.5m in total, so ensure that the sockets are close enough to reach (see diagram on previous page).

Extension cables should not be used with this appliance.

PRODUCT SPECIFICATION

Key Product Specifications	
Power supply	230V ~ 50Hz
Rated power (kW)	3.0 ¹
Weight (Kg)	255
Power connection	2 x 13A plugs
Required power source	2 x 13A plug sockets
Dimensions	985 x 900 x 640mm ²
Required space	991 x 1,375 x 650mm ³

¹ Does not include induction hob use.

² Does not include towel rail, door or bolster lids – See diagram for further details.

³ Increase required width by 34mm, when positioned next to wood worktops (ie, 20mm either side, rather than the standard 3mm either side for non-combustible materials).

VENTILATION

Care must be taken to ensure that the kitchen is well ventilated. Natural ventilation holes within the room must be left open, or install a mechanical ventilation device, such as an extractor hood.

5. INSTALLATION INSTRUCTIONS

WEEE Compliance Scheme Membership Number: WEE/MM2763AA



ESSE Engineering Ltd.,
Long Ing, Barnoldswick, Lancashire, **BB18 6BJ**

Website www.esse.com

R3 220630