

**BIOMASS / MINERAL FUEL  
FIREPLACE INSET THERMOSTATIC  
BOILER and ROOMHEATER**

**INSTALLATION AND OPERATING INSTRUCTIONS  
LEAVE THIS DOCUMENT WITH THE HOUSEHOLDER!**



Water	For use only with open-vented, indirect, water systems. Maximum pressure 2 bar. Can be inter-connected with combi boilers & other heat systems using Esse Centraliser Unit.		
Control System:	All-mechanical thermostatic air supply to fire in response to boiler temperature. No electrical connections or parts. Can be controlled by time clocks, room thermostat etc.		
Fireplace & Chimney:	For installation in masonry fireplace with a single dedicated chimney. Minimum flue draught 14Pa		
Clearance:	Physical space: 100mm around in-room parts. From combustibles: 150mm		
Extended Burn:	Variable with fuel, heat demand and chimney conditions. Anthracite = c12 hrs		
<b>MAXIMUM PERFORMANCE</b> With door closed, burning dry fuel with flue draught of 14Pa	<b>Biomass (Wood Logs)</b> (With type 395 Boiler)	<b>Mineral Fuel ('Ancit')</b> (With type 395 Boiler)	
Mean flue temperature: *	395 °C	364 °C	
Flue gas flow:	8.52 g/sec	13.6 g/sec	
Mean CO in flue (as if at 13% O <sub>2</sub> ):	0.4%	0.12%	
Efficiency: *	75.7 %	72.7 %	
Total output from appliance: *	14.7 kW (50,443 Btu)	14.6 kW (49,802Btu)	
Output to room:	3.6 kW (12,437 Btu)	2.8 kW (9,714Btu)	
Output to water:	11.1 kW (38,006 Btu)	11.8 kW (40,088Btu)	
Fuel per hour at maximum:	3.8 kg	2.4 kg	
Maximum achieved at refuelling interval of:	1 hr	2hr	
* NOTE: Figures are for heat from the appliance <b>only</b> . There will typically be additional, often substantial, heat gains from the masonry of the fireplace and chimney, and consequent higher total efficiency. Total performance for a particular building can be calculated by the method of EN13384			

**Manufactured by: Esse Engineering Ltd**  
**Long Ing, Barnoldswick, Lancashire BB18 6BN, England**  
[www.esse.com](http://www.esse.com)

This document, when completed by the installer, constitutes a 'Hearth Notice' for purposes of the England and Wales Building Regulations 2000, (App. Doc. J4). It must be left with the householder and placed where it can easily be found.

APPLIANCE SERIAL NUMBER:		Flue Draught measured on commissioning: <input type="text"/> Pa
INSTALLED AT LOCATION:	BY:	
EMERGENCY TELEPHONE:		<input type="text"/>
SIGNED:	DATE:	
Who certifies that this installation is safe, has been demonstrated to the householder, conforms with current building regulations and with these instructions		Fuel used on commissioning

**TO FIND A QUALIFIED INSTALLER, FUEL SUPPLIER or CHIMNEY SWEEP, CONTACT:**  
**UK:** The Solid Fuel Association, 7 Swanwick Court, Alfreton, Derbyshire DE55 7AS Tel:0845-601-4406 [www.solidfuel.co.uk](http://www.solidfuel.co.uk)  
**Rol:** Irish Nationwide Fireplace Organisation, 162 Capel Street, Dublin 1 Tel:01-801-5959 [www.fireplace.ie](http://www.fireplace.ie)

# Read these instructions! Use only recommended fuels!

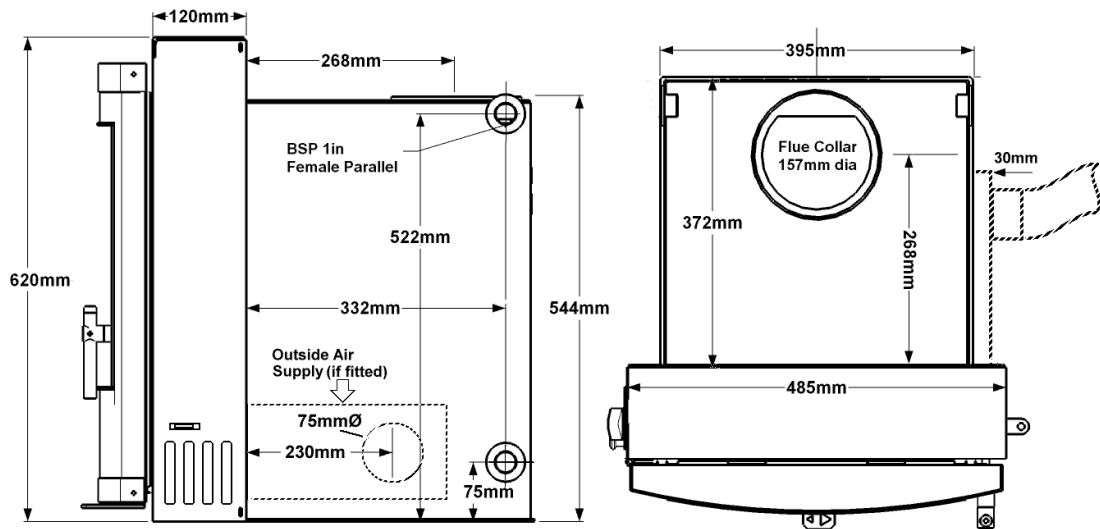

Welcome to more than one-hundred-and-fifty years of Esse. You join the illustrious tribe of Esse fire-keepers, from Florence Nightingale, Captain Scott, Mrs Beeton, Auguste Escoffier, Queen Victoria and most of the Royal Families of Europe to Fred Dibnah and Hugh Fearnley-Whittingstall.

## THIS APPLIANCE BECOMES EXTREMELY HOT AND CAN PRODUCE POISONOUS GASES.

A fire-guard should be used if children or the infirm are present. The installer is required to **EXACTLY** follow these instructions and to comply with all local, national and applicable international standards.

**LOCATION:** This appliance is heavy, a load distribution plate may be needed on weaker floors. The appliance must be located on a flat hearth extending at least 225mm in front of the fire, and of suitable material to protect the building from fire. Combustible materials, including fuels, must be at least 225mm away from the room parts of the appliance. This stove can fit into fireplace openings of 400 to 460mm wide and 550 to 590mm high. If the Outside air kit is used, fireplaces must be prepared with an extra opening to the lower right of the face, as shown.

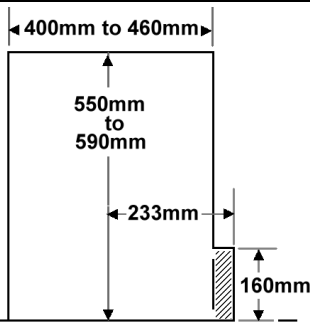

**YOUR CHIMNEY** makes your fire work. It stores surplus heat from the fire, which makes the gas inside its hollow flue lighter, so that it rises, pulling fresh air through the fuel and making it burn. The Greenswitch is for connection to a single flue which must be:

- Able to operate safely at temperatures of up to 500°C
- Free from even the slightest leak, and absolutely incapable of spilling fumes into the dwelling
- Smooth internally, unobstructed and able to be swept along its entire length.
- Generate a continuous up-draught in use of at least 14Pa (0.06insWG)

These ends will often be achieved by the chimney being constructed entirely of masonry or insulated metal components, having an internal size of more than 150mm but less than 300mm, being substantially vertical with no severe bends or horizontal portions, being at least 5m high and terminating at least 1m above any roof.

**AIR SUPPLY.** All fuels need a continuous supply of fresh air from to burn. There **must** be an air supply into the room from outside the building, incapable of being closed off and equal to a total of least 55cm<sup>2</sup> (=c7.5cm square). Leakage around doors and windows is not always sufficient, while an extractor fan or another fuel-using appliance, even in a different room, can remove this air and cause dangerous fume emission.

An **air supply kit** is available to bring combustion air directly from

outside the building to the GreenSwitch boiler, greatly reducing the risk of draughts and significantly improving performance.

## TYPICAL INSTALLATION INTO MASONRY CHIMNEY

This is the traditional method used in Britain and Ireland. Other methods of installation are possible – ask Esse for a leaflet.

**1: Dismantle the boiler.** If the unit is supplied assembled, lift off the top of the front and carefully pull the cylindrical brass thermostat sensor from its holder. Unfasten the 4 bolts shown, lift the front unit up slightly and carefully part the two units. Take very great care not to damage the soft seal.

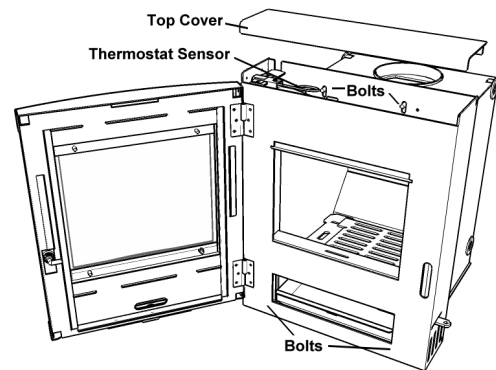

**2: Prepare the setting, fit and test the boiler.** Place the boiler/rear unit on a hearth which will extending at least 250mm in front of the assembled fire, noting that the final surface of the fireplace will be just behind the two flanges arrowed. In this example the air supply kit has been fixed to the side of the boiler with adhesive tape, prior to being cemented-in. Complete the piping circuit, fill and inspect for leaks as you won't be able to repair leaks later.

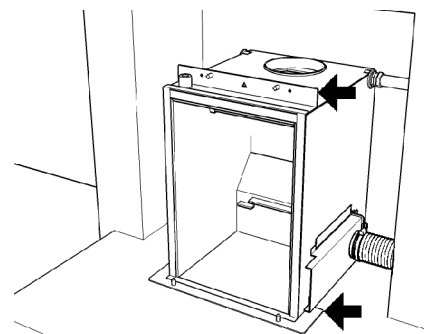

**3: Brick up and form the flueway.** Build-up a masonry wall around the boiler, forming a smooth connection to the flue with no ledges

where debris could collect. Fill any space with mortar-and-rubble.  
(Shown part-completed)

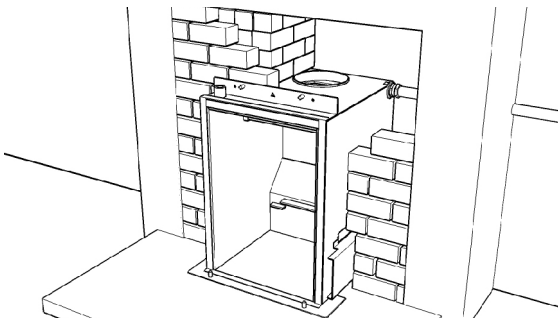

**4: Fit fireplace surround.** Slot a ready-made fireplace surround in place, or build one up using brick, stone or other masonry or metal materials. Extra fixing, if needed, is through the screw holes shown.

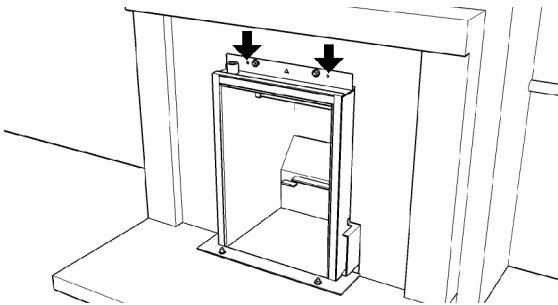

**5: Refit front and check thermostat:** Bolt the door/front unit back in place, taking great care that the parts seal. Reassemble the interior fittings and check that the door closes and seals properly. Push the thermostat sensor fully into its pocket, securing it with a dab of fire cement. The thermostat is a delicate instrument and, although it is tested and set at the factory, it may need re-adjusting.

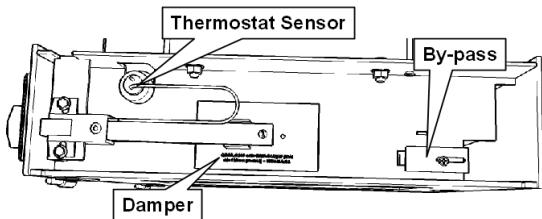

**6: Adjusting the thermostat:** With the fire cold, the thermostat sensor in place and the thermostat control turned to '1' the air closure 'damper' plate should be approximately 8 mm open. The By-pass allows a bleed of air to keep the fire going even when the thermostat closes-off. About half-open works well with most fuels and chimneys, but it may need experience to find the best position.

## HEATING SYSTEM

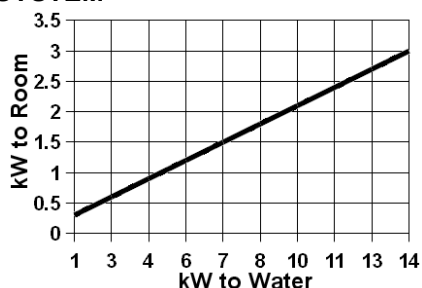

The GreenSwitch is an automatically controlled heating boiler – heat output into the room will vary as the demand for hot water varies, so it will almost always be wise to fit a radiator (with thermostatic valve) in the fireplace room.

The GreenSwitch is for connection to open-vented, indirect, water systems only, with a maximum working pressure of 2 bar. Every installation must include:

- A pipe thermostat to prevent the pump running if boiler flow temperature drops below c50°C. This prevents heat from stored hot water being dumped if the fire dies down and guards against condensation inside the boiler.

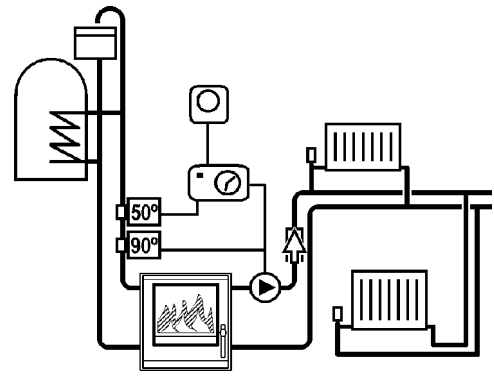

- A pipe thermostat set at about 90°C to run the pump and dissipate heat in the event of boiler overheating, irrespective of how other controls are set.
- Means to completely drain water from the system.
- A means of dissipating surplus heat, such as a permanently connected radiator or hot-water system.
- Means to allow steam to be released in case of complete thermostat and electrical failure.

### In addition, we recommend:

- Radiators fitted with thermostatic valves.
- An 'anti gravity' valve preventing circulation to upper radiators when the pump is not running.
- A room-temperature thermostat and single-circuit time-clock controlling the running of the circulating pump.

The diagram shown one possible arrangement.

**MULTI-BOILER SYSTEMS** with simultaneous automatic control of the GreenSwitch *and* gas, oil, cooker-boilers, heat stores, combi-boiler etc. can be achieved using an Esse Centraliser unit. Details are available separately.

**COMMISSIONING** The installer must complete the notice at the beginning of this document, demonstrate the method of lighting, control and cleaning, and point out the safety requirements to the householder.

## GETTING THE BEST FROM YOUR STOVE

Every fuel, chimney and condition of use is different. Only experience will show which is the best for you. We suggest trying several different fuels, or mixtures, and different settings of the controls.

**GREENSWITCH GETS VERY HOT-** Use a glove or the tool supplied to manipulate hot parts and controls.

**LIGHTING** After a period of non-use, do check the chimney for blockages first! Empty the ashes. Place two or three firelighters close together, or screwed-up paper covered with dry sticks, at the back of the grate and light them. When they are burning well gently fill the fire with dry fuel to the level shown. Don't over-fill or allow fuel to touch the throat plate.

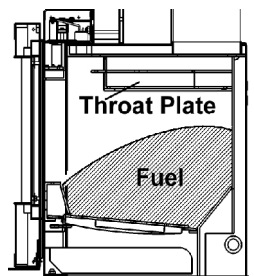

**EMPTYING ASHES** Use the tool to pull the de-ashing mechanism on the right-hand side of the fire back-and-forth. If it jams, don't force it but wait a few minutes for any obstructing fuel lump to burn away. Open the door and lift out the ashpan. Let ash cool before disposing in plastic bins. There is no need to empty every speck, but make sure that ash from mineral fuels never builds up so that it touches the underside of the grate, or the grate will melt.

**EXTENDED BURNING** Allow the fire to burn down to a low, hot fire bed. Empty the ash and well fill with smaller pieces of hard fuel such as anthracite.

**CLEANING** Wipe the body when cool. Soot will condense on the window if the fuel is damp or if the fire operates at low outputs for long periods. Deposits will normally burn-off when the next fast-burning cycle comes round, but persistent stains can be removed with a household bleach spray cleaner when the fire is cold.

**DOOR** Your GreenSwitch is designed to be operated only with the door closed. Open the door slowly to minimise fumes emission.

**AUTOMATIC CONTROL.** Your GreenSwitch has three controls.

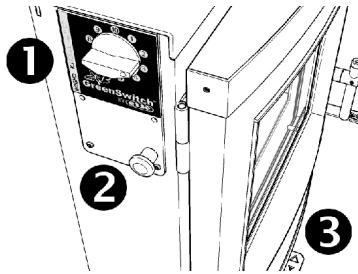

- 1) **Boiler thermostat.** This senses the temperature of water in the boiler and automatically allows air in to make the fire burn more or less fiercely, so that water always leaves the boiler at about 50°C on setting '1' to about 90°C at '10'.
- 2) **GreenSwitch control.** Diverts air above or below the fire. Simply pull out for wood, push in for mineral fuels like anthracite.
- 3) **Door air control,** a manual slide or spinwheel control. This overrides the thermostat and may usefully be opened a little to keep certain fuels 'ticking over'.

**FUEL** must be dry, with no dust or pieces smaller than about 40mm. **WOOD** is a renewable fuel, and, because a burning log can't give out any more carbon than the tree itself absorbed while living, it is considered to be greenhouse gas 'neutral'. Fresh wood may seem dry, but its cells are full of water. Burning such 'green' wood wastes heat in making steam and produces tarry condensation which will damage your appliance and chimney. Logs should be split and dried in a well-ventilated place for one to three years. **Only ever use thoroughly dried-out wood.** The white residue from burned wood is not ash, but cell walls which can burn if kept hot enough, so, with wood alone, don't de-ash the fire until absolutely necessary. **JOINERY WASTE** can be a useful fuel if **completely dry**, but don't use timber with preservatives as it can emit very poisonous fumes. **PEAT** The nearly black moorland or bog peat should be dried and treated as for wood.

**LIGNITE** is a mineral between peat and coal. It lights easily and burns well, though may produce excessive ash and smoke. **ANTHRACITE** is a natural hard, shiny, smokeless, form of coal. It burns with great heat and lasts a long time. **BRIQUETTES** are compressed blocks of fuel, generally able to burn for long periods and remarkable for their consistency. **NOT RECOMMENDED: PETROLEUM COKE** is very high in acid and will damage your appliance. **BITUMINOUS HOUSECOAL** is cheap, but rarely value for money, burns with violent flame and tarry smoke. It will stain the window, is difficult to control and can explode. **HOUSEHOLD WASTE:** Plastics create toxic fumes. Batteries & aerosols explode! Never use liquid fuels.

**SMOKE** Compliance with smoke regulations is the responsibility of the user. To ensure low smoke emissions on wood:

- 1) Make sure the fuel is **absolutely** dry (less than 15% water)
- 2) Split logs into pieces no more than about 100mm diameter.
- 3) Refill 'little and often'
- 4) Try to load logs 'criss-cross' so that plenty of air can circulate around them.

It is often beneficial to burn a little clean mineral fuel, such as anthracite, along with the wood.

**SUMMER SHUT DOWN:** Before a long period of non-use leave all the air controls open to allow ventilation to reduce condensation.

## PROBLEMS?

**NOT ENOUGH HEAT** Is fuel **really** dry? Is chimney draught correct? Are the room and fire controls set correctly? The GreenSwitch is designed to provide heat into water, when installed in a large room a radiator will be needed too.

**LACK OF CONTROL** Are the door seals sound? Some types of wood, lignite and coal are difficult to control.

**CONDENSATION** happens when water vapour touches a cool surface inside the fire, mixing with combustion products to make sticky tar. Water comes from the fuel. Even 'dry' wood may hold a 150mm cupful in every 1kg log. Prevent condensation by using only **absolutely dry** fuel and fit the correct thermostat to prevent cold water from circulating through the boiler.

**DIFFICULTY BURNING FOR EXTENDED PERIODS** The

GreenSwitch is thermostatic, it will keep on making the fuel burn vigorously for as long as there is a demand for heat, so, if water still circulates through radiators eg. at night, the fire will continue to burn – consider adding an 'anti-gravity' valve to stop unwanted circulation when the pump is off, or simply turn the boiler thermostat down at night. Are the door seals sound? Is the flue free from cracks? For longest burn use hard fuels like anthracite. Is the By-pass air control set correctly?

**SMOKE COMING INTO ROOM** Occasional fumes while loading or de-ashing may occur, but persistent emission to the room must not be tolerated. First and always, measure the chimney draught, it must be at least 14Pa in use. Causes of poor draught include:

**LEAKS:** Even the tiniest crack in the flue can spoil the draught. **BLOCKED FLUE:** Pull out the throat plate to inspect. In any case of doubt have the chimney professionally swept. **COLD FLUE:** Smoke only rises if kept hot. Is chimney fully insulated? **LACK OF FRESH AIR:** Make sure there is an unobstructed fresh air supply to the fire.

**DOWNDRAUGHT:** Wind can blow down the flue if there is something higher near the chimney such as a tree, hill or high building. Fit an anti-downdraught cowl to the chimney top.

**CHIMNEY FIRE:** In the rare event of deposits inside the chimney igniting (roaring sound + dense smoke and sparks from the chimney) immediately close the door, shut all air controls and call the fire brigade. Prevent fires by using **very dry fuel** and having your chimney swept regularly.

**DIRTY WINDOW.** Is fuel **absolutely dry**? The window will become dirty when the fire operates at low levels for a long time, but will usually self-clean at higher burn rates.

## MAINTENANCE

**EVERY MONTH** When the fire is cold, use the operating tool to pull forward and clean the throat plate. Check that the door seals are sound.

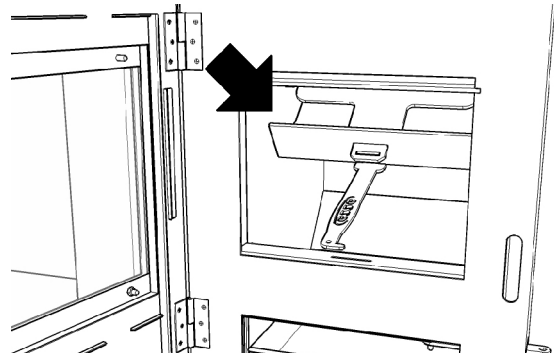

**ANNUALLY,** or more often if smoky fuels are used. sweep the entire length of the flue from firebox to chimney outlet.

**REPLACEABLE PARTS** Internal parts will last far longer if special care is taken to empty ash from mineral fuels regularly, to clean the throat plate and to use **completely dry** fuel. The GreenSwitch has been extensively tested for safety - please don't try to modify it and always make sure to get genuine spare parts.

Your GreenSwitch is guaranteed (excluding wearable parts) for one year from the date of purchase, in addition to your statutory rights.

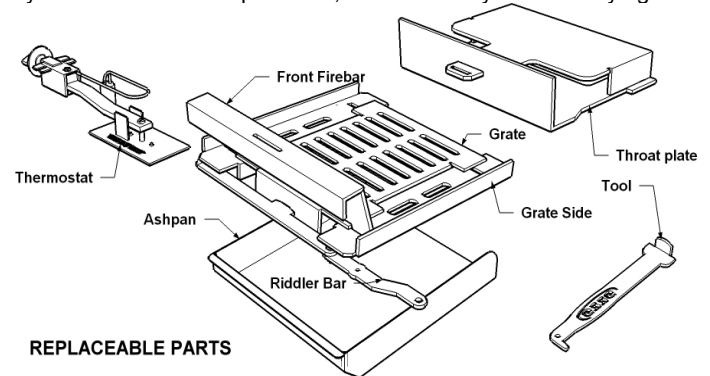

**REPLACEABLE PARTS**