

#### INFORMATION FOR USE WHEN ORDERING SPARES:

Model: \_\_\_\_\_

Serial Number: \_\_\_\_\_

Colour: \_\_\_\_\_

03/10 (PP)  
INSTR.CK-WN/u

# ESSE Woodfired Cooker

## OPERATING INSTRUCTIONS

MODEL: WN

### GUARANTEE

#### Conditions of Guarantee

Your ESSE cooker is guaranteed against defects arising from faulty manufacture for three years, subject to the following express conditions:

- This cooker must be commissioned by your ESSE Dealer (or an authorised HETAS engineer) upon installation. The details must be recorded on the Commissioning card and registered with ESSE by returning the completed card. The guarantee period commences upon delivery of the cooker (subject to receipt of the correctly completed card).
- The cooker has been used for normal domestic purposes only, and in accordance with the manufacturer's instructions.
- The cooker is serviced annually by the ESSE Dealer or authorised HETAS engineer, and the Service record completed. The cooker must not be serviced, maintained, repaired, taken apart or tampered with by any person not authorised by us.
- Any cooker or defective part replaced shall become the Company's property.

#### Exclusions

This guarantee does not cover:

- Parts deemed to be replaceable in the normal usage of the cooker. These parts are listed herewith: all firebricks, firebox bottom plate, combuster, airslider oven accessories.
- Enamel damage; the vitreous coating on your cooker is in effect an extremely thin layer of glass and as such displays all the characteristics of glass. It can easily be damaged by impact, or by spillage of cold liquids onto a hot surface. Such damage cannot be covered under this guarantee. (See also intermittent use of your cooker, below).

This guarantee is personal to the original purchaser and is non-transferable.

#### Intermittent use of your Cooker

In the event of intermittent use and prolonged shutdown, it should be noted that in some circumstances enamel may be displaced due to ingress of damp. Whilst this is rare, it is most likely to occur in situations where the unused cooker remains in a unheated property. There is a layer (known as the groundcoat) between the vitreous enamel surface and the cast iron. Groundcoat is porous and if exposed (e.g. after a chip in the vitreous enamel coat), may allow damp to penetrate behind the vitreous enamel and spread through the groundcoat. Surface oxidation of the cast iron may thereafter occur, causing the vitreous enamel to fall off. Such damage will not be covered by your warranty. We recommend that a light coating of petroleum jelly be applied to any damaged areas when the cooker is not in use to help keep out the damp, in addition to following instructions in your Operating manual.

#### Customer Care

In the event you should require spare parts, please order through your ESSE dealer.

Should you have cause for dissatisfaction with your cooker, you should contact your ESSE dealer, who will, in most instances, be able to offer you immediate assistance. You will be required to give the following details.

- Your name, address and postcode.
- Your telephone/contact details.
- Clear and concise details of the fault.
- Model and serial number of the cooker (found on the inside panel of the control oven door).
- Purchase date (please note that a valid purchase receipt or guarantee documentation is required for in-guarantee service calls).

We will then check that we have an accurately completed warranty card, if not then any work carried out may be charged.

We will assess the nature of the complaint and either send replacement parts for your dealer to fit, send an engineer to inspect & report, or send an engineer to remedy. If the fault is not actually due to faulty workmanship but some other cause such as misuse or failure to install correctly, a charge will be made to cover the cost of the visit and any new parts required, even during the warranty period. Home visits are made between 08.30-1700 hrs Monday to Friday, and are arranged for either a morning or afternoon appointment.



Esse Engineering Limited, Long Ing, Barnoldswick, Lancashire BB18 6BN

Tel: 01282 813235 Fax: 01282 816876 e-mail: enquiries@esse.com

Website: <http://www.esse.com> On-line Store: <http://www.esseparts.com>



THIS APPLIANCE MUST BE COMMISSIONED BY A HETAS REGISTERED ENGINEER  
THE WARRANTY CARD MUST BE RETURNED TO ENSURE GUARANTEE VALIDITY



## INTRODUCTION

We are pleased that you have chosen an ESSE Woodfired range cooker. We would ask you to read the following instructions very carefully. Correctly installed and operated, your ESSE will give satisfactory service for many years. We feel certain that you will enjoy the warmth and comfort of your ESSE and, perhaps more importantly, you will more than enjoy the superb quality of the cooking.

## CONTENTS

Safety Notes	Page 2	Operating the Oven & Hob	Page 6
Your Cooker	Page 3	Types of Fuel	Page 6
Before Using Your Cooker	Page 4	The Hotplate	Page 6
Tools & Accessories	Page 4	Flueway Cleaning	Page 7
Lighting & Controlling the Fire - De-ashing	Page 5	Guarantee	Page 8

## SAFETY NOTES

- All local regulations, including those referring to national and European standards need to be complied with when installing the appliance.
- A suitable and compliant flue is essential for this appliance to operate properly. It must be capped to prevent ingress of rain and regulated with a flue regulator where there is excessive draught. External flues must be insulated (see installation instructions). Failure to connect this appliance to a suitable, properly working flue will seriously inhibit the cooker's performance.
- Properly installed, operated and maintained, this appliance will not emit fumes into the dwelling. However, occasional fumes from de-ashing and re-fuelling may occur. Persistent fume emission is potentially dangerous and must not be tolerated. If fume emission does persist, open doors and windows to ventilate the room. Let the fire burn out or eject and safely dispose of fuel from the appliance. Once the fire is cold, check the flue and chimney for blockages and clean if required. Do not attempt to re-light the fire until the cause of the fume emission has been identified and corrected. Seek expert advice if necessary.
- An adequate air supply for combustion and ventilation is essential. Air openings provided for this purpose must not be restricted. Also if simultaneous operation of other heating appliances is required within the kitchen ensure that there is sufficient ventilation.
- Should it be likely that children, aged or infirm people approach the appliance whilst the fire door is open, then a fireguard manufactured in accordance with **BS 6539** should be used. Also warn children not to sit or stand on the appliance or use it as a 'step-stool' to access cupboards or shelves etc. above the appliance.
- Care must be taken not to close the inner firebox door against any logs protruding from the fire. Damage to the inner door lining will occur. See label.
- Avoid the use of aerosol sprays in the vicinity of the cooker when it is in operation and do not heat any unopened airtight containers.
- Ensure that precautions are taken when deep fat frying, never leave the appliance unattended and ensure you have fire safety equipment available such as a fire blanket in case of emergency.
- When operating the cooking stove use the tools provided and follow these instructions carefully.



### WARNING

Do not place towels on the handrail, keep pets and children away and ensure that any curtains near the appliance cannot ignite even when displaced. Surfaces will be hot when in use.

## YOUR COOKER

Your woodfired range cooker is a combination appliance providing a hot plate, fast and slow ovens. The air-slider is used in conjunction with the firebox door for initial light up and subsequential burning rate control. The firebox door has a 2-stage catch. Closed in position 1 the door is locked slightly ajar to boost primary air for hotter temperatures and position 2 closes the door completely (see Fig. 2). Do not use logs which are too long as they can damage the lining on the rear of the firedoor.

The firebox linings i.e. brick and steel base are to remain permanently fixed in position.

There are two hinged stainless steel lift up covers to conserve heat losses from the hotplate when it is not in use.

A flue damper is fitted in the bottom of the flue box and is in the open position when the lever is pointing to the rear of the cooker. This is used in initial light up and also gives a cooler oven temperature when open. (see Fig. 3a).

The cooker has two ovens; the upper oven is fitted with a thermometer for general use and a lower oven suitable for slow cooking and warming.



### IMPORTANT

During cooking ensure steam vents (see Fig.1) in both ovens are kept clear so any cooking steam is properly vented away via the flue.

Fig. 1 - Your Cooker

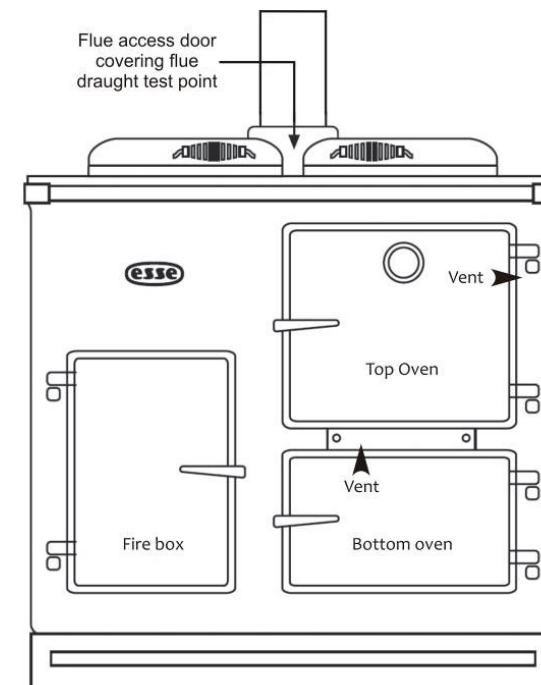

## BEFORE USING YOUR COOKER

Check that the plastic protection coating has been removed from each hotplate cover, and from the inside of the doors. This should have been done during installation but if the plastic has been left on it will melt on firing the cooker and cause damage to the linings.

The hotplate surface should be wiped with a dishcloth or similar, which has been soaked with hot water and a detergent liquid. Finally dry off the hotplate with an absorbent material.

Fig. 2 - Two Stage Door Catch

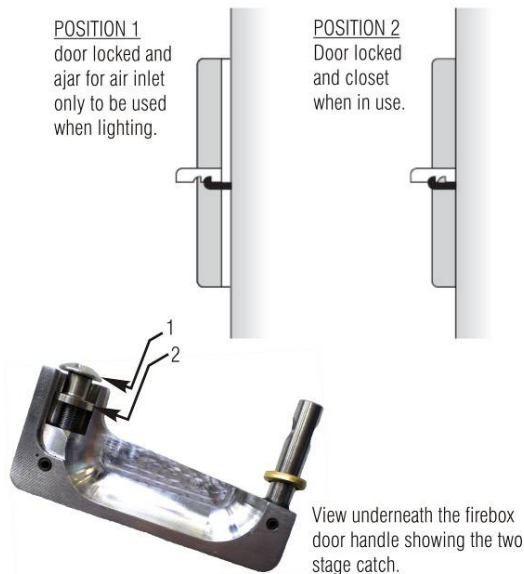

## TOOLS AND ACCESSORIES

The following items are supplied with your ESSE cooker:

### Accessories:

- Roasting Tin (x1)
- Baking Tray (x1)
- Wire Shelves (x2) fit in either oven
- Glove (x1)

### Tools:

- Wire Brush (x1)
- Ash Shovel (x1)
- Lifting Tool (x2) for lifting off the Hotplate
- Flue Rake (x1)
- Flexible Flue Cleaning Brush (x1)

Fig. 4 - Tools for Cleaning and Maintenance



## LIGHTING AND CONTROLLING THE FIRE

In order to light the fire check that the flue damper is in the open position (see Fig. 3a) and the fluebox door is closed. Open the firebox door. Open the primary air slider (on inner firebox door). Open the inner firebox door and place paper, kindling and small logs on the floor of the firebox and light. Close the inner and outer firebox doors to the first catch position (see Fig. 2) and leave the fire for 20 minutes to become established and then re-fuel. Close the firebox door. Once the fire is established and the ovens are up to the required temperature, use the primary air slider to control the burning rate and oven temperature. Try not to re-open the firebox door after refuelling for at least 20 minutes, as it is likely to smoke back out of the door. By closing the flue damper (see Fig. 3b) the oven will become hotter.

The cooker must not be run with the firebox door open. When you need to refuel the fire, open the door slowly, to avoid smoke and flames entering the room.

Secondary air enters over the top of the fire through built-in air vents in the combustion box and works continuously by design.

The flue box door is fitted with a screw control (see Fig. 3a). This may be fully or partially opened, to reduce the flue pull on the fire and thus air extended burning times. Its effect is dependant upon prevailing flue conditions, which may vary according to wind and weather. If there is any sign of smoke leakage from this control, ensure it is closed.

### Fuel Loads

The firebox can be loaded to capacity or as required depending on your usage requirement. Do not force wood into the firebox and always ensure that the fire door can be closed without touching the loaded logs.

### Slow Combustion

In order to achieve overnight burning a layer of ash needs to be built up in the firebox, when this is done load the firebox and close the primary air slider, flue damper and firebox door. Avoid opening the firebox door until next required. Overnight burning is best achieved using properly seasoned firewood. To re-inflame, use kindling wood first before adding larger logs.

In the event of a chimney fire close all cooker controls and take appropriate action. (see page 6).

If the draught strength in the chimney is too much, overnight burning may not be possible without fitting a stabiliser.

To boost the hotplate or oven temperature - open the firebox door and open the primary air slider for 10 to 15 minutes. To boost the hotplate temperature and not oven - open the damper in the flue (see Fig. 3a).

Open the fluebox door using the screw control (see Fig. 3a) to slow down the burning rate of the cooker, for example when a cool oven is required.

DO NOT use a poker when tending the fire, this could damage the brick lining.

### De-ashing

Only remove small amounts of ash from the firebox. When de-ashing, leave 30mm to 40mm depth of ash in the bottom of the firebox for the best performance. Always use the glove to open and close the door. Never hang tea towels or material above the fire door when the door is open on the first catch setting, or when re-fuelling or de-ashing.



Your cooker should not be used as an incinerator and only recommended fuels shall be used.

NOTE

## OPERATING THE OVEN AND HOB

The temperature of the hotplate is graduated from left to right. The left side is hotter and so is used for boiling and the right side is for simmering. The hotplate should never be removed whilst there is a live fire in the firebox.

The oven doors and firebox door are opened by lifting the handles manually (note they will become hot during use, so please use a gloved hand).

The oven and hob are heated directly by the fire. Once the fire is established the flue box damper should be closed (pulled forward). This position will force the heat from the fire to circulate around the flue ways, thus heating up the hob and the oven.

The hob lids can be left down when the hob is not in use to keep the hotplates warm. In order to reduce oven temperature the flue damper should be in the open position. This will allow heat to escape directly up the chimney.

The temperature gauge on the oven door only provides an indication of the oven temperature, but since it is in the door itself, the thermometer will react to show the oven temperature but the reaction will be slightly delayed as opposed to instantaneous.

The ovens are fitted with anti-pull out stops to prevent shelves from being pulled out accidentally. To remove the shelf pull forward until stops, lift the front end, pull out of oven. Use reverse procedure to refit the oven shelves.

## TYPES OF FUEL

### Wood

For best results use well seasoned hardwood such as Oak, Ash or Beech. Allow wood to dry out under cover in well-ventilated conditions for at least twelve months. Wood is ready for burning when radial cracks appear in the end of logs. Burning wood that is not seasoned will result in tar being deposited in the cooker and flueways.

This build-up of tar is a hazard and if it ignites may cause a chimney fire. In the event of a chimney fire, close the air controls on the appliance and call the fire brigade for assistance. Resinous softwoods burn well and give a high output for short periods but is not as efficient and do not last as long as hardwood.



### WARNING

This appliance is not suitable for use with solid mineral fuels, e.g. Coal, Coke, Anthracite, etc.

## THE HOTPLATE

The hotplate is surface ground and intended for use with machined base utensils. As heat passes from the hotplate to the utensil almost directly by conduction, good contact is essential and a thin-bottomed utensil will result in poor heating performance, especially if the bottom is uneven.

It is important to use pots and pans that have a ground base and are flat-bottomed on the hotplate. Cookware made of stainless steel, cast iron, aluminium, glass and earthenware is suitable for your ESSE. The hottest part of the hotplate is the left-hand end while the area over the oven is cooler. Quick boil on the former and then transfer for simmering on the latter. For deep fat frying, bring to temperature on the 'right' side. Introduce cold food and then return to temperature on the 'hotter' side.

Cooking directly on the hotplate is another facility - griddle scones, burgers, sausages, steaks and even Welsh Rarebit can be cooked directly on the surface.

Meringues can be dried on a baking tray sitting on the hob overnight.

Additionally, by using a barbecue griller you can produce your own toasted sandwiches on the top oven.

The hotplate can be rubbed down with a proprietary cleaning pad if necessary, but normally should need no attention unless spillage is allowed to harden on its surface.

Always keep hotplate covers down except when using the hotplate.

## SHUTTING DOWN PROCEDURE

Allow the fire to burn out and close all air controls.

### Long Term Shut Down

If the cooker is to be shut down for long periods i.e. during summer months or if the appliance is in a second home that is not used all the time, precautions should be taken to avoid damage from condensation and corrosion. If possible remove the hotplate and leave all air controls open and the bolster lids up to ensure maximum ventilation of the appliance whilst not in use for long periods.

## MAINTENANCE AND FLUEWAY CLEANING



The fire must be out and the cooker cold.

### IMPORTANT

Used correctly with properly seasoned firewood your cooker will not need professional maintenance or servicing. Regular home maintenance is however essential to keep the cooker working optimally. This includes periodic cleaning of the cooker's flueway.

In order to clean the flueway of the cooker, first remove the hotplate screws and lift it clear of the cooker using the two hotplate lifting handles. Also remove the fluestrip plate located between the two oven doors and the fluebox door. Use the flue cleaning brush and flue rake to gather the soot and ash towards the front of the ovens then remove using a flex-nozzle vacuum cleaner. **DO NOT use the cooker when any of the access points are removed.**

See separate maintenance guide for more information about regular maintenance and cleaning. It is recommended that the chimney and flue connected to the cooker are cleaned annually by a qualified chimney sweep.



### NOTE

Where the chimney is believed to have served an open fire installation it is possible that a higher flue gas temperature from a closed appliance may loosen deposits that were firmly adhered, with the consequent risk of flue blockage. It is therefore recommended that the chimney be swept a second time within a month of regular use after installation.

## Consumable Spare Parts

1. Secondary Combustion Grid (shown right)
2. Brick Linings
3. Ash Pit Base

