

#### INFORMATION FOR USE WHEN ORDERING SPARES:

02/10 (PP)  
INSTR.CK-EW/u

Model: \_\_\_\_\_

Serial Number: \_\_\_\_\_

## GUARANTEE

### Conditions of Guarantee

Your **ESSE** cooking stove is guaranteed against defects arising from faulty manufacture for two years, subject to the following express conditions:

1. A suitably qualified person must install the appliance, and upon installation the details must be recorded on the warranty card and registered with **ESSE** by returning the correctly completed card. The guarantee period commences upon delivery of the cooking stove.
2. The appliance has been used for normal domestic purposes only, and in accordance with the manufacturer's instructions.
3. The appliance has not been serviced, maintained, repaired, taken apart, or tampered with by any person not authorised by us.
4. An approved dealer or representative must undertake all service work under this guarantee.
5. Any cooker or defective part replaced shall become the Company's property.

### Exclusions

This guarantee does not cover:

- Damage or calls resulting from transportation, improper use or neglect.
- Parts deemed to be replaceable in the normal usage of the appliance. These parts are listed herewith: ashpan, bottom grate, front bar, firebox linings, hotplate cover seals, door glass, door seals.

This guarantee is personal to the original purchaser and is non-transferable.

### Customer Care

In the event you should require spare parts, please order through your **ESSE** dealer.

Should you have cause for dissatisfaction with your cooking stove, you should contact your **ESSE** dealer who will, in most instances, be able to offer you immediate assistance. You will be required to give the following details:

- Your name, address and postcode.
- Your telephone/contact details.
- Clear and concise details of the fault.
- Model and serial number of the cooking stove (found on the data plate behind lower right door).
- Purchase date (please note that a valid purchase receipt or guarantee documentation is required for in-guarantee service calls).

We will then check that we have an accurately completed warranty card, if not then any work carried out may be charged. The nature of the complaint will be assessed and either replacement parts for your dealer to fit, an engineer to inspect & report, or an engineer to remedy will be arranged. For any home visits that may be required, an appointment will be made for either morning or afternoon, Monday to Friday.

If the fault is not actually due to faulty workmanship but some other cause such as misuse or failure to install correctly, a charge will be made to cover the cost of the visit and any new parts required, even during the warranty period.



Esse Engineering Limited, Long Ing, Barnoldswick, Lancashire BB18 6BN

Tel: 01282 813235 Fax: 01282 816876 e-mail: enquiries@esse.com

Website: <http://www.esse.com> On-line Store: <http://www.esseparts.com>

# ESSE Cooking Stove

## OPERATING INSTRUCTIONS

MODELS: EW & EWB



THIS APPLIANCE MUST BE COMMISSIONED BY A HETAS REGISTERED ENGINEER  
THE WARRANTY CARD MUST BE RETURNED TO ENSURE GUARANTEE VALIDITY



## INTRODUCTION

We are pleased that you have chosen an ESSE cooking stove. We would ask that you read the following operating instructions very carefully.

Correctly installed and operated, your ESSE cooking stove will give satisfactory service for many years.

We feel certain that you will enjoy the warmth and comfort of your ESSE cooking stove and, perhaps more importantly, you will more than enjoy the superb quality of the cooking.

BON APETIT!

## TABLE OF CONTENTS

Safety Notes	Page 2	Extended Wood Burning	Page 8
Your Cooking Stove	Page 3	Wood & Peat Fuel	Page 8
Lighting and Controlling the Fire	Page 5	Solid Mineral Fuel	Page 9
Operating the Oven and Hob	Page 6	Shutting Down Procedure	Page 10
Notes on Wood Burning	Page 7	Cleaning and Maintenance	Page 11
Correct Running Temperatures	Page 7	Guarantee	Page 12

## SAFETY NOTES

- Properly installed, operated and maintained, this appliance will not emit fumes into the dwelling. However, occasional fumes from de-ashing and re-fuelling may occur. Persistent fume emission is potentially dangerous and must not be tolerated. If fume emission does persist, open doors and windows to ventilate the room. Let the fire burn out or eject and safely dispose of fuel from the appliance. Once the fire is cold, check the flue and chimney for blockages and clean if required. Do not attempt to relight the fire until the cause of the fume emission has been identified and corrected. Seek expert advice if necessary.
- An adequate air supply for combustion and ventilation is essential. Air openings provided for this purpose must not be restricted.
- Should it be likely that children, aged or infirm people approach the appliance whilst the fire door is open, then a fireguard manufactured in accordance with **BS 6539** should be used. Also warn children not to sit or stand on the appliance or use it as a 'step-stool' for access to cupboards or shelves etc. above the appliance.
- Avoid the use of aerosol sprays in the vicinity of the cooking stove when it is in operation and do not heat any unopened airtight containers.

- Ensure that precautions are taken when deep fat frying, never leave the appliance unattended and ensure you have fire safety equipment available such as a fire blanket in case of emergency.
- When operating the cooking stove use the tools provided and follow these instructions carefully.



### WARNING

Do not place towels on the handrail, keep pets and children away and ensure that any curtains near the appliance cannot ignite even when displaced. Surfaces will be hot when in use.



### WARNING

An extractor fan must not be fitted in the same room as this appliance.

## YOUR COOKING STOVE

Fig. 1 - The Cooking Stove

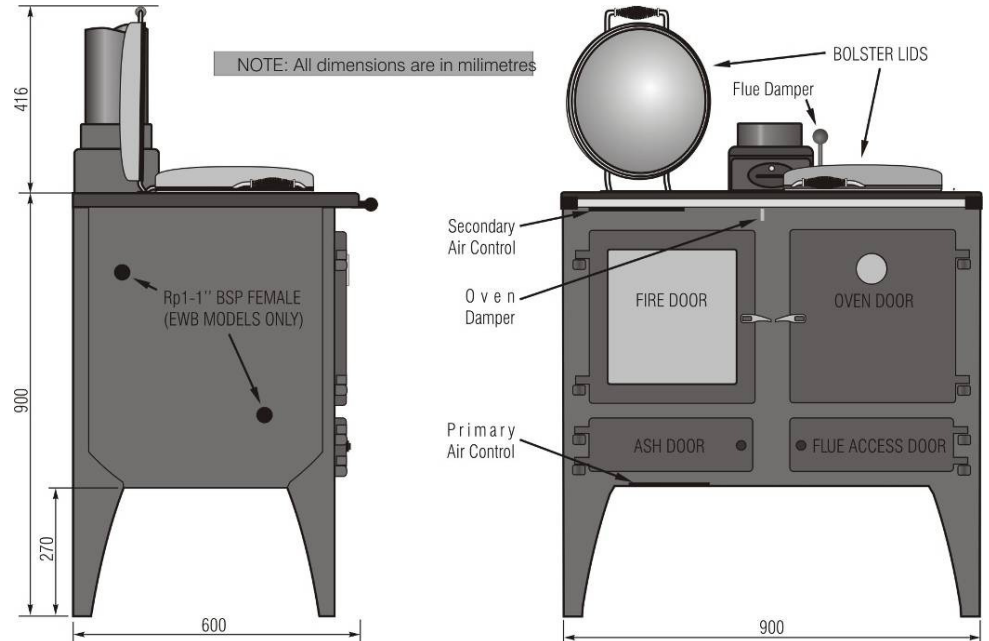



NOTE

- Primary Air Control** - slide LEFT to open
- Secondary Air Control** - slide LEFT to open
- Oven Damper** - PULL to open
- Flue Damper** - PUSH back to open

Fig. 1 shows the cooking stove and its controls. The large glass door on the left is the loading door through which the fire is lit and refuelled. The small door at the bottom on the left is the ash door. The large door to the right of the cooking stove is the oven and the small door at the bottom right is the oven flue access door.

Included inside your cooking stove is a multi-purpose Operating Tool - for lifting the ash pan, adjusting the primary and secondary air supply and opening the doors. A glove is also provided to protect the user's hand.

The cooking stove is suitable for burning wood and smokeless solid fuels.

A flue damper (Fig.1) is fitted in the bottom of the fluebox and is in the open position when lever is pointing to rear of cooker. This is used on initial light-up and also gives a cooler oven temperature when open. It can also help to control excessive flue draught. This is done by pointing the lever to the front of the cooker.



NOTE

This appliance is not an incinerator and only recommended fuels should be used. Ordinary bituminous house coal is not recommended and must not be burned. Burning bituminous house coal will result in a sooty cooking stove and chimney, and the fire door glass will require regular cleaning. Pure petrocokce should also be avoided as the high temperatures this fuel can produce may damage the cooking stove.

Fig. 2 – Operating Tool and the Glove

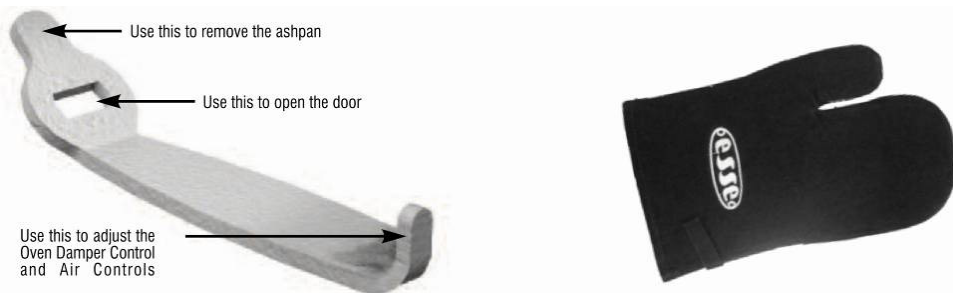

## LIGHTING AND CONTROLLING THE FIRE

Fig. 3a - Multi-fuel version. Firebox parts

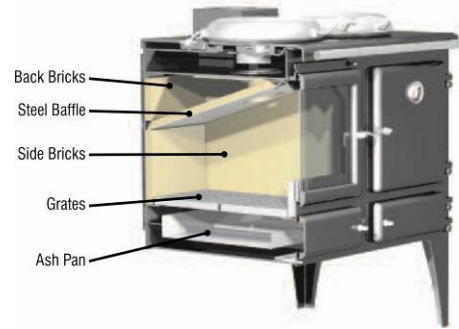
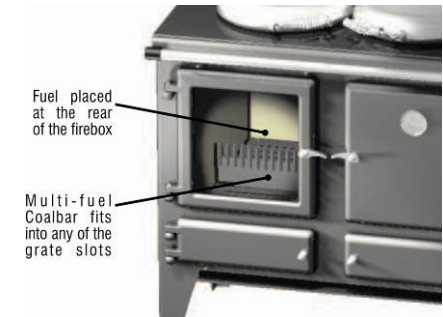

Fig. 3b - Multi-fuel version. Alternative flue bar posi-



NOTE

Wood burning model has no grate or ashpan. A special wood burning box is fitted in the firebox in place of grate and ashpan.

Before lighting ensure that all the internal components are in the correct position. (see Fig. 3).

Open the ash door on the bottom left of the cooking stove by inserting the Operating Tool (See Fig. 2) into the handle slot and turning it in an anti-clockwise direction.

Fig. 1 on page 3 shows the primary air control lever on the left. Push the lever left to open and right to close. To light the cooking stove the primary air control should be fully open.

Open the loading door by lifting the handle either manually or using the Operating Tool.

Fig. 1 shows the secondary air control to the left and the damper control to the right. As with the primary air control, the secondary air control lever should be pushed left to open and right to close. The damper control is open when the knob is pulled out and closed when it is pushed in.

To light the cooking stove the secondary air control should be fully open and the damper control pulled out. The flue restrictor should be opened by pointing the lever to the rear of the cooker (Fig. 1). This will allow fumes to escape directly up the flue whilst the cooking stove warms up.

Place some tightly rolled paper on top of some crumpled paper on the base towards the back of the cooking stove. On top of this, place some small pieces of wood. Light the crumpled paper and close the door.



When the cooking stove is running ALL HANDLES become hot and the Operating Tool alone should then be used.

**WARNING**



**EWB model only**

Do not light the appliance if there is a possibility that any part of the water system is frozen.

**WARNING**

## Wood

Once the fire becomes established add some larger pieces of wood. As the cooking stove comes up to temperature close the primary air control.

The burning rate of the cooking stove can now be regulated by the rate at which fuel is added and by adjusting the secondary air control.

The maximum amount of fuel to be loaded is 3kg in order to achieve nominal heat output using one hour re-fuelling periods.

## Solid fuel

Once the fire becomes established add some solid fuel. The rate at which solid fuel burns can be controlled by using the primary air control and by the amount of fuel added. The secondary air control will affect the burning rate to a lesser degree than the primary, but it should be left open where possible in order to keep deposits away from the glass window.

Whichever fuel is used, the oven damper control may be closed once the fire is established depending on oven requirements. For more detail on solid fuel see page 9.

## OPERATING THE OVEN AND HOB

The temperature of the hob is graduated from left to right. The left side is hotter and so is used for boiling and the right side for simmering. The oven door and the fire door are opened by lifting the handle either manually or using the Operating Tool provided.

The oven and hob are heated directly by the fire. In order to heat up the oven and hob the fire should be lit as described above. Once the fire is established the oven damper should be pushed in. This will allow the hot fumes from the fire to circulate around the inner cavity between the cooking stove and the oven thus heating up both the hob and the oven.

The hob lids can be left down when the hob is not being used in order to keep the hotplates warm. In the up position they will allow more heat into the room.

To reduce the heat going to the oven when the cooking stove is up and running, the oven damper knob can be pulled out. This will allow the hot fumes to escape directly up the chimney via the boiling side of the hotplate, thus reducing the heat to the oven but maintaining a hot hotplate.

To maintain a good cooking temperature in the oven the cooking stove requires only a small amount of fuel. To reduce the effective size of the firebox, the fuel bar can be moved towards the back and thus used to hold a smaller amount of fuel at the rear of the firebox, see Fig. 3b. This also has the advantage of reducing the heat radiated through the window, making life easier for the cook. Also the fireguard can be slid in front of the fire door in order to reduce the heat through the glass and protect the operator whilst cooking.

The temperature gauge on the oven door provides an indication of the oven temperature. It should be noted however that since the gauge is attached to the door, the indicated temperature will drop if the door is left open for any prolonged period, in which case, the oven may be hotter than it is indicated on the dial. Once the door is closed again, the gauge will come back to temperature.

## NOTES ON WOODBURNING

Wood burns most efficiently when the air for combustion is supplied from above the fire bed rather than below. The air supplied above the fire bed provides the oxygen necessary for the volatile gases (smoke), given off by the wood as it heats, to combust. This ensures that the gases are burnt and used to heat the appliance instead of being wasted up the chimney or condensing and forming tarry deposits inside the cooking stove, in the flue or on the loading door glass.

Running the cooking stove with the primary air control open and the secondary air control closed will provide oxygen for the wood to burn on the fire bed but will not provide air for the volatile gases above the fire bed to combust resulting in a smoky inefficient fire.

With the above in mind the cooking stove should ideally be run with the primary air inlet closed and the secondary air control open whenever possible. Another advantage of running the cooking stove with the air wash open is that the air being drawn into the cooking stove travels across the glass, forming an air barrier between the glass and the fire bed, helping to prevent smoke particles sticking to the glass.

If the fire dies down too low, opening the primary air control for a short period will revive it.

## CORRECT RUNNING TEMPERATURES FOR WOOD BURNING

To get the best results from your cooking stove it is recommended that a wood stove thermometer (available from your cooking stove dealer or [www.esseparts.com](http://www.esseparts.com)) be fitted to the flue pipe above the cooking stove, at eye level if possible. The figures below show the recommended temperature of the flue gases.

**115°C - 245°C (240°F - 475°F)**

The flue gases should be in this temperature band for the safest, most efficient and most economical operation of your cooking stove.

**Below 115°C**

This is below the condensation point of wood gases and may cause the build up of tar in the chimney, dirty the cooking stove glass and result in the inefficient burning of fuel.

Too hot. Heat will be wasted up the chimney. Excess heat may damage the cooking stove or ignite an existing accumulation of tar resulting in a chimney fire. In the event of a fire, close the air controls on the appliance and call the fire brigade for assistance.

### EXTENDED WOOD BURNING

This appliance has not been certified as a slow combustion stove. Loading a large amount of wood into the cooking stove all at once will reduce the temperature inside. If the temperature is too low, the gases given off from the wood will be too low to combust, resulting in a lot of smoke which will cover the inside of the cooking stove, including the glass, with soot. To combat this problem it is a good idea to increase the temperature of the cooking stove before loading by further opening the air inlets. Load the wood and leave the air controls open until the moisture is driven out of the wood and the cooking stove is back up to an efficient operating temperature. The air inlets can then be reduced to hold the temperature of the cooking stove. If excessive flue updraught is experienced, pull the flue restrictor lever to the front of the cooking stove to reduce the flue draught (Fig. 1). Loading the cooking stove little and often will help keep its temperature steady.



#### NOTE

The above text should be used as a guide only. The ideal operation of your cooking stove depends on a number of factors, which vary with each installation, and so gaining experience operating your cooking stove is the only way to learn its best operation.

### WOOD & PEAT FUEL

#### Wood

---

The maximum acceptable log length is 500mm.

For best results use well seasoned hardwood such as Oak, Ash or Beech. Allow wood to dry out under cover in well-ventilated conditions for at least twelve months. Wood is ready for burning when radial cracks appear in the end of the logs. Burning wood that is not seasoned will result in tar being deposited in the cooking stove, on the glass and in the flueways.

This build up of tar is a hazard and if it ignites, may cause a chimney fire. In the event of a chimney fire, close down all controls and call the fire brigade for assistance. Resinous softwood burns well and gives a high output for short periods but is not as efficient and does not last as long as hardwood.

#### Peat

---

Peat is a fuel conveniently available in some areas and should be burned in the same manner as wood.

### Ash Removal

---

Wood burns best on its own ash and a manageable layer of ash on the grate is a benefit to the efficient running of your cooking stove. To empty the ashes from the ashpan below the grate, open the door at the bottom left of the cooking stove using the Operating Tool (Fig. 2) by connecting the tool to the door handle and turning anti-clockwise. Insert the tool into the slot on the ash pan and pull forwards and lift to remove. Care should be taken when disposing of ashes that are still warm. They should not be put into a plastic receptacle or anything that might melt in contact with heat.

Always use the Operating Tool to open the ash door and remove the ashpan.

When burning solid fuel, ash will need to be removed regularly, taking care to prevent ash from building up underneath the grate which can damage the appliance and impair performance.

Always use the Operating Tool to securely lock the door and ensure the door is closed properly.

### SOLID MINERAL FUEL

#### Lighting and Controlling the Fire

---

Before lighting the fire for the first time, ensure that the baffle and the side and back bricks are in position. Burning without either will result in the stove castings overheating and being damaged.

Open the secondary air control and the primary air control fully. Place some tightly rolled paper on top of some crumpled paper on the base towards the back of the cooking stove. On top of this, place some small pieces of wood and on top of that a few small pieces of mineral fuel. Light the crumpled paper and close the door. Once the fire becomes established and the fuel is burning, more fuel can be added. When the stove is hot and the fuel is no longer producing smoke, the secondary air control can be reduced. The burning rate of the fire can now be controlled with the secondary air control. As air from the primary air control flows up through the grate it will cool the grate bars preventing them from overheating and becoming damaged. Reducing the primary air control and introducing only secondary air control will allow the fuel to burn but the grate will not be cooled resulting in possible damage to the grate. When controlling the fire, the primary air control should be altered gradually. Reducing the primary air dramatically and all at once on a hot cooking stove will cause the fuel to clinker and will result in a build up of gases and smoke which could ignite with a bang the moment air is reintroduced.

#### Extended Burning

---

Before adding a large amount of fuel, the grate should be de-ashed and the ashpan emptied. Add the fuel sloping it from the front coal bar up to the back of the stove to the level of the top of the back brick. Open the primary air control and let the fire burn for a period on high rate in order to get the stove back up to temperature, reduce the secondary air control and reduce the primary air control to suit the burning rate. The exact setting of the air controls depends on a number of variables including: the flue draught, the fuel used and the installation, and so the best setting for your cooking stove can only be learned by experience.

## Ash Removal

---

The level of ash should not be allowed to build up to the level of the grate. If the level of ash becomes too high the air through the grate will become restricted causing the grate bars to overheat and preventing the fuel from burning efficiently.

## Mineral Fuels

---

Ordinary bituminous house coal is not recommended and must not be burned in smoke control areas. Burning bituminous house coal will result in a sooty stove and chimney, and the door glass will require cleaning regularly. There are numerous natural anthracites and manufactured smokeless fuels that will burn cleanly and have more reliable burning characteristics. A list of these fuels and their suitability is produced by HETAS ([www.hetas.co.uk](http://www.hetas.co.uk)). Consult your local fuel merchant to find out what is available in your area. Petro-coke should not be used as it burns very hot and may damage the cooking stove castings.

## SHUTTING DOWN PROCEDURE

Allow the fire to burn out and close all air controls.

### Long Term Shut Down

---

If the cooking stove is to be shut down for long periods i.e. during summer months or if the appliance is in a second home that is not used all the time, precautions should be taken to avoid damage from condensation and corrosion.

If possible, remove the hotplate and leave all air controls open and the bolster lids up to ensure maximum ventilation of the appliance whilst not in use for long periods.

## CLEANING AND MAINTENANCE

It is important that flue ways are cleaned frequently and the chimney swept regularly. Also the cooking stove must be maintained in good mechanical order by a qualified heating engineer/technician. Regular sweeping means at least once per year for smokeless fuel and a minimum of twice a year for other fuels.

If the chimney was previously used for an open fire, ensure any obstructions or dampers are removed or locked open. The cooking stove operates at higher flue gas temperatures, deposits of soot and debris that were firmly adhered to the inside of the chimney, when it was used with an open fire, can loosen and cause a blockage. We recommend that in such a situation a second sweeping of the chimney should be carried out within one month of regular use of the cooking stove after installation.

The cooking stove should only be cleaned when it is cold. The exterior can be dusted with a firm brush. Do not use a cloth to clean, as this will drag on the paint finish leaving lint on the surface.

As the cooking stove top is used for cooking, normal wear and tear will occur. Spills should be mopped up immediately with a damp cloth, but oven cleaners should not be used on the hob surface.

The exterior of the cooking stove is painted with high temperature resistant cooking stove paint and from time to time it may become necessary to renovate the exterior by repainting. The surface must be prepared by rubbing down with a wire brush. The cooking stove paint will not key to the surface if there are fat deposits or food particles on the area to be resprayed. High temperature resistant cooking stove paints are available in aerosol form from your cooking stove dealer, or from [www.esseparts.com](http://www.esseparts.com). Do not use this paint until the cooking stove is completely cold and always follow the instructions on the container before starting to paint. The usual precautions should be taken, such as covering adjoining surfaces and protecting the hob lids.

The hob lids are made of stainless steel. These have been treated with oil at the factory to prevent fingerprints and marks forming. The lids can be wiped clean with a damp cloth and proprietary stainless steel cleaners may be used. It is recommended that after such cleaning, the lids be again treated with oil by wiping over with a lint free cloth. This will prevent fingerprints and smears. Baby oil or similar is recommended for this purpose.

The fire door glass should stay relatively clean if the correct type of fuel is used as described above, but from time to time this can be cleaned when cold with a proprietary glass cleaner and a dry cloth, or depending on soot build up, a nylon pan scourer. Vinegar and newspaper may also successfully be used.



### NOTE

Please refer to the separate maintenance guide for more detailed information about cleaning and maintenance of ESSE wood-fired appliances.

---