

REPLACEMENT PARTS

COMMON	Part No.
Burner	GAS-006 W
Catalyser	CAT-030
Catalyser Seal	CAT-031
Piezo Igniter	2023-099 BO
Piezo H.T. Lead	2023-146 BO
Solenoid	2023-157 D
PROPANE/LPG ONLY	
Control Valve	2023-093L
Oxypilot	GAS.PILOT-L/P451
NATURAL GAS ONLY	
Control Valve	2023-093 BO
Oxypilot	GAS.PILOT-N/P441

When ordering replacement parts, quote the cooker serial number and gas type.



Esse Engineering Limited, Long Ing, Barnoldswick, Lancashire BB18 6BN

Tel: 01282 813235 Fax: 01282 816876 e-mail: enquiries@esse.com

Website: <http://www.esse.com> On-line Store: <http://esseparts.com>

GAS FIRED COOKERS

INSTALLATION & COMMISSIONING INSTRUCTIONS

MODEL: CAT - Enabled



THIS APPLIANCE MUST BE COMMISSIONED BY A GAS SAFE REGISTERED ENGINEER
THE WARRANTY CARD MUST BE RETURNED TO ENSURE GUARANTEE VALIDITY

HEALTH & SAFETY AT WORK ACT 1974 (AND AMENDMENTS)



The installer has a responsibility under this Act, to provide for the safety of person(s) carrying out the installation.

Attention is drawn to the following:

- 1) The appliance is heavy and requires care in handling. Lifting off the pallet and positioning may be carried out using the Lifting Jack* available from ESSE dealers. There may also be sharp edges on certain components.
- 2) Fire cement is caustic and hands must be washed thoroughly after use.

Although this appliance does not contain asbestos products, it is possible that asbestos may be disturbed in existing installations and every precaution must be taken.

*Patent applied for.

IMPORTANT:

This cooker must be installed in accordance with regulations in force and only used in a well ventilated space. Read these instructions before installing or using.

GAS CATEGORIES:

Natural Gas Models - 2nd Family - I₂H
Propane Gas Models - 3rd Family - I₃P

COUNTRY OF DESTINATION:

GB AND IE

TABLE OF CONTENTS

General Information	Page 3	Maintenance and Servicing	Page 8
Building in the Cooker	Page 4	Fault Finding Chart	Page 12
Gas Control System	Page 5	Commissioning Record	Page 12
Oven Control	Page 5	Service Record	Page 13
Commissioning	Page 7	Replacement Parts	Page 16

GENERAL INFORMATION

The installation of the cooker, the chimney, hearth and walls adjacent to the cooker must be in conformity with local or national regulations currently in force. In the United Kingdom, the appropriate sections of the Building Regulations must be conformed to. The cooker weighs 300kg (662lbs) approx. The floor must be solid, level, and constructed in accordance with any Building Regulations which apply to the particular site. The cooker is supplied fitted for either or LPG or Natural Gas, and the fuel type is marked on a data label fixed to the inside of the burner chamber door. The cooker must not be installed in a bedroom, bathroom or any sleeping area. Additionally, a LPG cooker must not be installed in high rise flats or basements. Check the data plate specifications correspond to the available gas supply before starting installation.

Kitchen/Room Volume

The kitchen or room size in which the cooker is installed must be at least 15m³ (530ft³). This volume may include adjacent spaces but these spaces must not be separated.

Ventilation

As this appliance has no flue and is intended to be fitted into a kitchen, Building Regulations require an openable window (to outside).

An extractor hood directly over the cooker may be fitted.

Gas Service

Check that the gas meter and service pipe are both of adequate size to meet the requirements of the cooker and any other appliances that may be fitted on the system.

BUILDING IN THE COOKER

Fig. 1 - Your Cooker

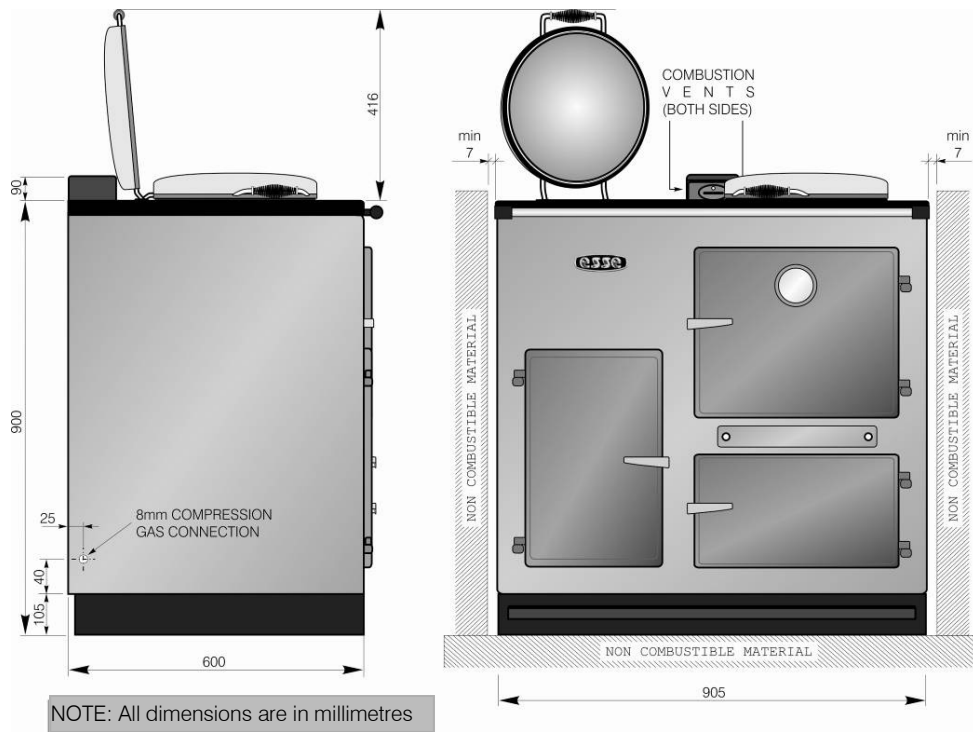

Space Requirements

Refer to Fig. 1

The minimum recommended width of space required to take the cooker is 920mm (36"). The minimum recommended clearance height above the cooker top is 600mm (23½")

Provision is made in the left hand side panel for service connections.

Clearances are not necessary on either side or rear of the cooker for non combustible material. For combustible material, ensure at least a 7mm (¼") gap on either side and rear of the cooker.

Where the rear wall is of combustible material, current regulations for the installation of heating and cooking appliances must be complied with. Building regulations say when fitting your gas appliance against a combustible wall you can either leave a 75mm (3") air gap or fit up to within 25mm (1") against a 25mm board of non combustible insulation. The cooker is supplied assembled and ready for connection to gas. The gas connection is 8mm compression in the gas tap at the lower left hand rear. No more than 1.5m of 8mm diameter pipe must be used to avoid unnecessary pressure drops.

Procedure for Assembly

Unpack the cooker completely and check all loose parts against the checklist provided. Inspect for any transit or other damage. For ease of movement, the three doors can be removed and stored carefully to avoid damage. Move the cooker into its final position and make gas and electrical connections as necessary. Place the fluebox loosely on the hob.

Replace the three doors, the shelves and roasting tin. Check the hotplate is level. Check that the hotplate covers lift easily and stay in the upright position when raised.

Remove the plastic protection from the hotplate covers and from the inside of the oven doors.

GAS CONTROL SYSTEM

Gas enters at the left hand side of the cooker via the 8mm compression connection. A square head service cock is provided. It is ON when the inscribed line is in line with gas flow. Appliances are despatched from the factory with the cock in the ON position and must remain in that position unless it is required to turn it OFF for servicing etc. (Figs. 4, 5, 6, & 7).



It is not recommended that the gas control is turned below setting 1 or 2 to pilot only as condensation is likely to occur from a cold start.

NOTE

OVEN CONTROL

This is a multi-functional control incorporating a thermo-electric flame failure valve, rotary tap and thermostatic control. The thermostat (100°C - 300°C / 212°F - 572°F) terminates in a phial clamped to the inside of the oven. This control is connected to the oven burner.

A 7-day electronic timer is fitted as standard.

A by-pass valve is also fitted for use in event of electrical power not being available.

The burner has a pilot, thermocouple and igniter.

Electricity Supply

The appliance requires a main electrical supply of 230 volts AC 50hz. This supply must be earthed and provided with a 3 amp fuse. One cable is supplied which is live to the electronic timer (Fig. 3).

Technical Information

GAS	NATURAL GAS (G20)	NATURAL GAS (G25)	NATURAL GAS (G20 & G25)	PROPANE (G31)
Category	I ₂ H	I ₂ L	I ₂ E & I ₂ E+	I ₃ P
Heat Input Max (Gross)	5.6kW	5.6kW	5.6kW	5.1kW
Heat Input Min (Gross)	1.25kW	1.2kW	1.25kW	1.1kW
Supply Pressure	20mbar	20mbar	20mbar	37mbar
Burner Pressure High	18.2mbar ± 0.2mbar	23.8mbar ± 0.5mbar	18.2mbar ± 0.2mbar	36.7mbar ± 0.5mbar
Burner Pressure Low*	1.2mbar ± 0.2mbar	1.3mbar ± 0.5mbar	1.2mbar ± 0.2mbar	2.0mbar ± 0.2mbar
Injector Size (Burner)	BRAY 82/360	BRAY 82/380	BRAY 82/360	BRAY 92/160
By Pass Injector (Solenoid)	BRAY 960/70	BRAY 960/70	BRAY 960/70	BRAY 960/16
Oxypilot	P441	P412D	P441	P451
Gas Connection	8mm compression or ¼" BSP	8mm compression or ¼" BSP	8mm compression or ¼" BSP	8mm compression or ¼" BSP
Gas Consumption (High)	0.53m³/h	0.62m³/h	0.53m³/h	0.2m³/h
Countries	AT, CH, CZ, DK, ES, FI, GB, IT, LT, LV, NO, PL, PT, SE,	NL	BE, DE, FR, LU	BE, CH, CZ, ES, FR, GB, GR, IE, PL, PT

* With the manual/timer valve in manual position

Fig. 2 - The Control Panel

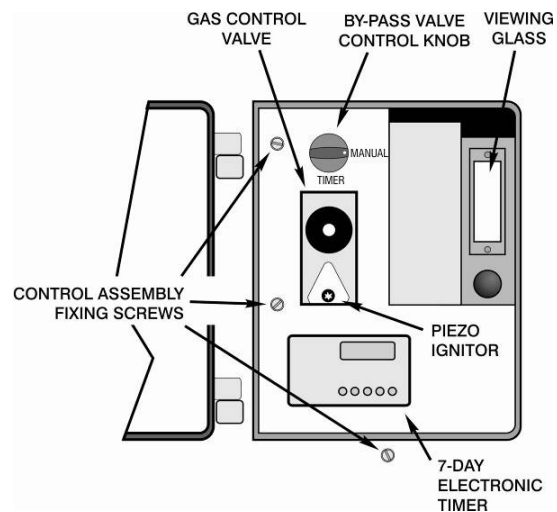
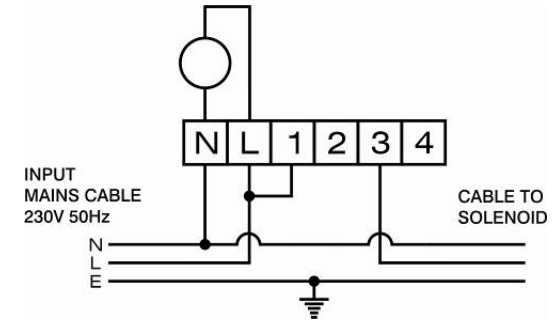

Fig. 3 - Wiring Instructions for Horstmann Electronic Timer



NOTE

Terminal 4 is only live when the Horstmann Timer is calling for heat.

COMMISSIONING

With the cooker installed and connected to gas and electricity proceed as follows:-

- 1) Pull off the by-pass control knob. Remove control panel, using the three control assembly fixing screws (Fig. 2), connect pressure gauge to test point on control inlet (Fig. 5). Check to ensure that appliance is ON.
- 2) Purge the pipework system of air. This can be done via the pressure test point or by holding the gas control lighting button until gas flows from the pilot.
- 3) Light the pilot. Leave main burner OFF. Check the pilot flame length through the inspection glass - flames should be approx. 20mm (¾") long.
- 4) Refer to the users instructions. Lift the hotplate covers to the upright position and light the burner. Check that the supply pressure is in accordance with that given in the Technical Information Table on page 6. Turn the main burner off, remove the pressure gauge, replace the pressure test screw and test for gas soundness. Replace the controls panel and by-pass control knob. Light the burner. Allow the cooker to heat up for 45 minutes. Because of the initial cold mass of metal, there will be some initial condensation and/or steaming but this should disappear as the cooker heats up. The hotplate covers are raised to prevent initial condensation affecting the soft seal fixative, wait 15 minutes, then turn the oven control knob to its lowest setting and check that the oven burner flame reduces to low rate - a flame length of about 3mm (¼") over the burner. Turn the burner down to No. ½ ready for future use.

Fig. 5 - Control Assembly

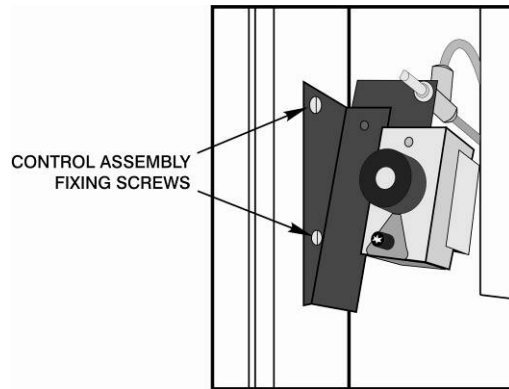

MAINTENANCE & SERVICING

Eurosit Control Valve

This is a single knob multifunctional control incorporating thermoelectric flame failure protection together with a thermostatic section using a phial type sensor. The thermostat will modulate the gas rate over its specific range and then down to the snap-off position.

The inlet and outlet connections are R³/₈" Female. Double inlet and outlet connections are available and the unused connection is plugged off. This must not be disturbed. The unit contains a restart interlock to avoid re-ignition safety i.e. when turned off the control must be allowed to stand in the OFF position for several minutes before the burner can be relit. The pilot may light but will go out as soon as the knob is released.

The gas rate to the burner is fixed by an adjusting screw in the outlet plug. This plug must not be interfered with since unscrewing will affect the gas input. The screw is sealed with paint before despatch.

The minimum rate screw also has an adjusting screw and must not be interfered with.

A piezo igniter is included within the cover assembly. This cover is fixed by one screw at the upper front.

Operation

Refer to Users Instructions - Turn knob to ignition position, press knob fully inwards and light pilot, release knob after 10 seconds, turn to full on position.

Pilot Rate Adjustment

Pre-set - no adjustment required.

Minimum Rate Adjustment

Pre-set - no adjustment required.

To Remove Parts

Burner Chamber Door - simply lifts off.

Controls Panel - Remove three screws (Fig. 2)

Heatshield - Remove two wing nuts. Lift off the heatshield.

Burner/Controls/Pipework Removal (Figs. 4, 6, & 7)

Burner assembly - Remove parts as described above. Isolate gas supply. Undo union on burner supply at control. Remove two screws fixing burner assembly to combustion chamber. Remove two screws fixing controls assembly (Fig. 4) Remove whole assembly.

Pilot Assembly - Pull off igniter lead at electrode. Undo union nut on pilot supply at control. Undo union nut on thermocouple. Remove lint arrestor. Remove two screws from underside of pilot bracket. Remove whole assembly.

Burner from Assembly - Undo union nut on injector. Remove two nuts from underside of burner.

Injector - Remove burner end plate (two screws). Remove injector locating nut.

Eurosit Control & Solenoid - Undo union nut on each end of the supply from service cock to control. Remove supply pipe. Undo union nut on pilot supply. Undo thermocouple fixing nut. Pull off igniter lead. Open oven door, remove two screws securing Eurosit fixing bracket to the cooker frame. Remove valve and solenoid.



IMPORTANT

The thermostat phial and capillary pass between cooker front and combustion chamber and can lead to difficulty when replacing. To avoid this, sellotape a length of thin string or wire to the end of the phial before removing it from the oven. Feeding the string through as the capillary is withdrawn. This will provide a guideline when the new control is fitted.

Servicing

The cooker should be serviced once each year by an authorised person. The following parts should be removed and cleaned as detailed below.

Hotplate

Care must be taken with the hotplate when removing or replacing as damage can occur to the enamelled surface. Remove the two hotplate securing screws and lift out the hotplate using the two screwed tools supplied to the user. Brush the underside with a wire brush.

Burner Assembly

Remove burner/controls/pipework as previously described. Check top surface for any dust or debris. Brush down as necessary. On completion, replace all parts.

Cooker Interior (Burner Chamber)

Sweep out any debris from the burner chamber, use a vacuum cleaner nozzle if necessary. At no time during servicing should the gas rate screw and the low flame screw be disturbed.

Catalyser (Fig. 9)

Remove catalyser mounting plate complete with catalyser and carefully clean if necessary with a soft brush.

Re-assemble all components in reverse order.

1. Check high and low burner setting pressures as described in 'Commissioning' Section.
2. If a combustion catalyser is available check the combustion performance of the cooker as follows:
 - Light the cooker and after 15 minutes check that the combustion performance of the cooker at the combustion vents is in accordance with the table below.
 - If the CO figures are more than that given in the table this suggests the catalyser is incorrectly fitted, or needs changing.

Table: CO/CO₂ emissions

CO	Less than 20ppm
CO ₂	Approx 3.0 - 4.0%

Fig. 5 - Eurosit Control Valve (Side view)

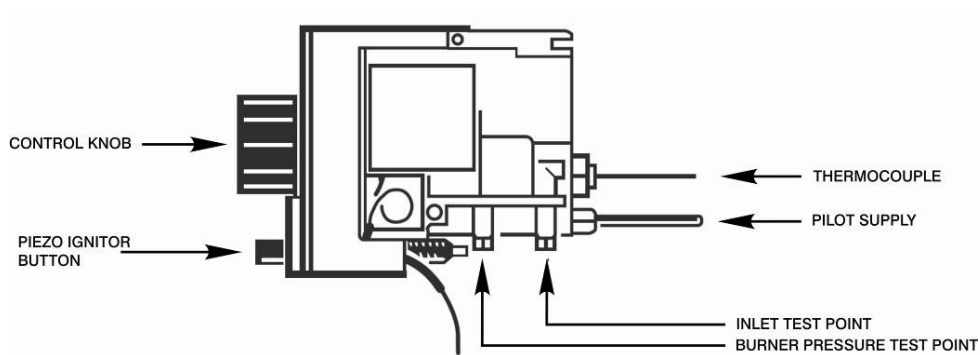

Fig. 6 - Eurosit Control Connections and Rate Screws

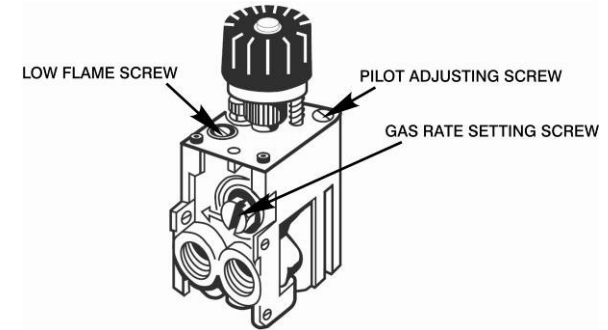

Fig. 7 - Gas Components - Schematic Arrangement

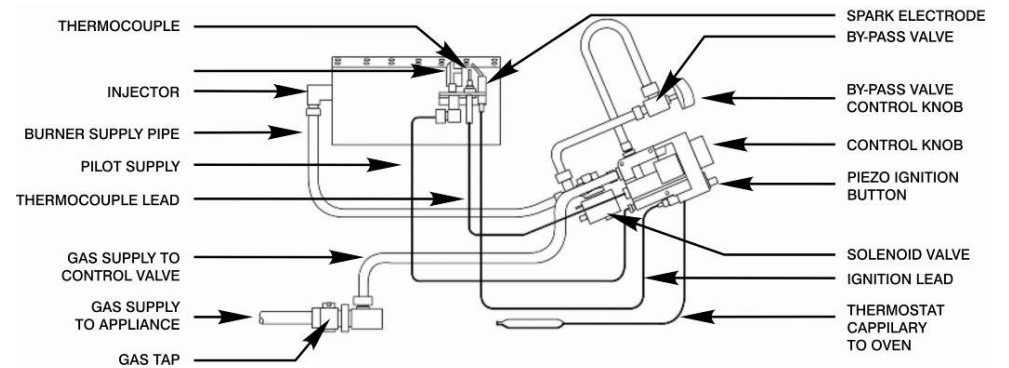
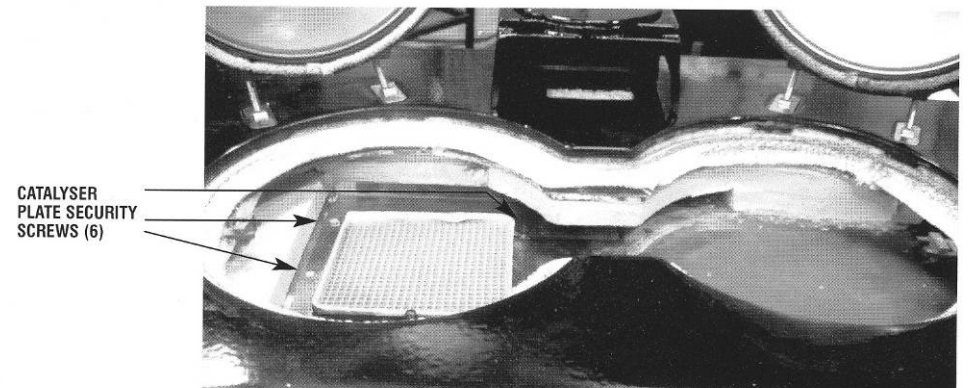

Fig. 8 - Catalyser



COOKER FAULT FINDING CHART

SITUATION	POSSIBLE CAUSES	REMEDIES
No gas to pilot	Isolation valve closed	Open isolation valve
	Pilot blocked	Remove and clean pilot assembly or replace
No spark to pilot	Piezo lead detached	Connect piezo lead
	Spark gap incorrect	Adjust spark gap
	Piezo faulty	Replace piezo
	Piezo lead faulty	Replace piezo lead
Pilot light won't stay lit or keeps going out	Dirty/loose thermocouple connection	Tighten/clean thermocouple connection into rear of gas valve
	Faulty thermocouple	Replace pilot assembly
	Pilot flame too short	Remove and clean pilot assembly or replace
	Blocked lint arrester	Clean lint arrester
	Fuming out from draught diverter causing oxygen depletion pilot to shut off	Correct poor draught
Oven stays too hot	Minimum rate set too high	Re-set minimum rate
	Thermostat faulty	Change control valve complete with thermostat
Oven stays too cool	Thermostat faulty	Change control valve completely
Cooker not heating	Burner cutting down	Increase cooker thermostat setting
	Burner cutting down control valve complete	Faulty thermostat - replace
	Utensils not flat	Use machine utensils

COMMISSIONING RECORD

Engineer's Name	<input type="text"/>	Date	<input type="text"/>
Address	<input type="text"/>		
	<input type="text"/>		
	<input type="text"/>		
Tel No.	<input type="text"/>	Fax No.	<input type="text"/>
Gas Safe Reg No.	<input type="text"/>		

SERVICE RECORD

Engineer's Name	<input type="text"/>	Date	<input type="text"/>
Address	<input type="text"/>		
	<input type="text"/>		
	<input type="text"/>		
Tel No.	<input type="text"/>	Fax No.	<input type="text"/>
Gas Safe Reg No.	<input type="text"/>		

Engineer's Name	<input type="text"/>	Date	<input type="text"/>
Address	<input type="text"/>		
	<input type="text"/>		
	<input type="text"/>		
Tel No.	<input type="text"/>	Fax No.	<input type="text"/>
Gas Safe Reg No.	<input type="text"/>		

Engineer's Name	<input type="text"/>	Date	<input type="text"/>
Address	<input type="text"/>		
	<input type="text"/>		
	<input type="text"/>		
Tel No.	<input type="text"/>	Fax No.	<input type="text"/>
Gas Safe Reg No.	<input type="text"/>		

Engineer's Name	<input type="text"/>	Date	<input type="text"/>
Address	<input type="text"/>		
	<input type="text"/>		
	<input type="text"/>		
Tel No.	<input type="text"/>	Fax No.	<input type="text"/>
Gas Safe Reg No.	<input type="text"/>		

Engineer's Name	<input type="text"/>	Date	<input type="text"/>
Address	<input type="text"/>		
	<input type="text"/>		
	<input type="text"/>		
Tel No.	<input type="text"/>	Fax No.	<input type="text"/>
Gas Safe Reg No.	<input type="text"/>		

Engineer's Name	<input type="text"/>	Date	<input type="text"/>
Address	<input type="text"/>		
	<input type="text"/>		
	<input type="text"/>		
Tel No.	<input type="text"/>	Fax No.	<input type="text"/>
Gas Safe Reg No.	<input type="text"/>		

Engineer's Name	<input type="text"/>	Date	<input type="text"/>
Address	<input type="text"/>		
	<input type="text"/>		
	<input type="text"/>		
Tel No.	<input type="text"/>	Fax No.	<input type="text"/>
Gas Safe Reg No.	<input type="text"/>		

Engineer's Name	<input type="text"/>	Date	<input type="text"/>
Address	<input type="text"/>		
	<input type="text"/>		
	<input type="text"/>		
Tel No.	<input type="text"/>	Fax No.	<input type="text"/>
Gas Safe Reg No.	<input type="text"/>		

Engineer's Name	<input type="text"/>	Date	<input type="text"/>
Address	<input type="text"/>		
	<input type="text"/>		
	<input type="text"/>		
Tel No.	<input type="text"/>	Fax No.	<input type="text"/>
Gas Safe Reg No.	<input type="text"/>		

Engineer's Name	<input type="text"/>	Date	<input type="text"/>
Address	<input type="text"/>		
	<input type="text"/>		
	<input type="text"/>		
Tel No.	<input type="text"/>	Fax No.	<input type="text"/>
Gas Safe Reg No.	<input type="text"/>		

Engineer's Name	<input type="text"/>	Date	<input type="text"/>
Address	<input type="text"/>		
	<input type="text"/>		
	<input type="text"/>		
Tel No.	<input type="text"/>	Fax No.	<input type="text"/>
Gas Safe Reg No.	<input type="text"/>		

Engineer's Name	<input type="text"/>	Date	<input type="text"/>
Address	<input type="text"/>		
	<input type="text"/>		
	<input type="text"/>		
Tel No.	<input type="text"/>	Fax No.	<input type="text"/>
Gas Safe Reg No.	<input type="text"/>		