

STOVE GUARANTEE

CONDITIONS OF GUARANTEE

Your ESSE stove is guaranteed against defects arising from faulty manufacture for 1 year subject to the following express conditions. Failure to comply with these conditions will invalidate the guarantee.

- Your ESSE dealer or a suitably qualified engineer must install the stove. Upon installation the receipt must be kept as proof of purchase.
- The guarantee is 1 year from date of purchase.
- The guarantee does not cover parts deemed to be replaceable in the normal usage of the stove. These parts are: firebars, ashpan, side and back bricks, base protection plates, baffle, door rope seal, fuel bar, door glass.

MULTI-FUEL STOVES

INSTALLATION & USER INSTRUCTIONS

(U.K & IRELAND)

ESSE 300 / Furnesse

READ THESE INSTRUCTIONS.

LEAVE THIS DOCUMENT WITH THE HOUSEHOLDER.

CONSTRUCTION CONFORMS
EN 13240
TO EUROPEAN STANDARD

RATED PERFORMANCE:

With the door closed, burning Anthracite at 0.93kg per hour with flue draught of 12Pa, air-control spinwheel 4mm open:

| | |
|---|---------------------|
| Mean flue temperature: | 381 °C |
| Mean CO in flue (as if at 13% O ₂): | 0.27% |
| Efficiency: | 64% |
| Output: | 4.5 kW (15,300 Btu) |
| Flue gas mass flow: | 6.6 g/s |



Ouzledale Foundry Co. Limited, Long Ing, Barnoldswick, Lancashire BB18 6BN
Tel: 01282 813235 Fax: 01282 816876 Email: esse@ouzledale.co.uk Website: <http://www.esse.com>

www.esse.com



BEFORE YOU BEGIN

This document is a guide to installation of the 300 stove, you are still required to comply with all local, national and European standards and regulations.

SOME WARNINGS!

ASBESTOS: The ESSE 300 does not contain asbestos, but take care to avoid disturbing any asbestos when removing an old installation.

WEIGHT: The ESSE 300 is heavy (66 kg) - protect your spine by moving the stove only with assistance. Ensure that the intended fireplace can support this weight- consider fitting a load distributing plate if necessary.

FUME EMISSION: Properly installed and operated this appliance will not emit fumes into the dwelling. Occasional fumes from de-ashing and refueling may occur, but persistent fume emission is potentially dangerous and must not be tolerated.

YOUR CHIMNEY

Your chimney creates the draught which your ESSE 300 needs in order to work - it must:

- Conform to local building regulations.
- Be at least 5m high.
- Terminate at least 1m above any roof ridge.
- Have an internal cross-section not less than 0.018m² - (eg 150mm dia) and not more than 0.14m² - (eg 375 x 375mm)
- Be free from even the slightest crack or source of leakage.
- Have no bends sharper than 45 degrees.
- Be entirely free of obstructions and swept by a qualified chimney sweep.

HEAT: The surfaces of this appliance will become extremely hot, while air can be emitted from the outlet grilles at up to 350°C - a fireguard should be used if children or the infirm are present. All combustible materials must be at least 250mm away from the fire, flammable materials (including fuel) should never be stored near to the appliance and the air outlet grilles on the stove must never be covered.

CHIMNEY FIRES: In the rare event of a chimney fire - usually identified by a roaring sound and dense clouds of black smoke and sparks exiting the top of the chimney - immediately close the door of your 300, shut the air control spinwheel and call the fire brigade. Prevent fires by having your chimney swept at least annually, or more often if smoky fuels are used.

- Be connected only to the one appliance.
 - Have a wall thickness of at least 100mm throughout its length, or be thoroughly insulated
- New masonry chimneys should be fitted with ceramic liners of at least 200mm diameter. Prefabricated chimneys should be of at least 150mm internal diameter, conform to BS4543 Part 2 and be installed in accordance with the manufacturer's instructions.

AIR SUPPLY

Your ESSE 300 needs air to breathe - there MUST be a permanent, unobscured, air supply into the room in which the fire is installed equal to at least 15cm. An extractor fan, or another fuel-using appliance, even in a different room, can remove this air.

FITTING

The ESSE 300 is designed for fitting only into a single chimney and a standard masonry fireplace conforming to BS1251 & BS8303, which must be made of incombustible materials (tile, brick, stone etc), and extend:

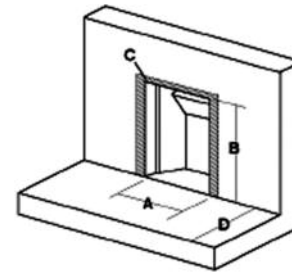

- At least 150mm all around the fire
- Have a hearth at least 150mm thick (which may include the thickness of a solid floor) extending at least 300mm in front of the appliance.
- Have a fireplace opening width (A) of between 400 and 460mm, an opening height (B) of between 540 and 560mm, a substantially flat area (C) extending 50mm around the opening, and a hearth at least 400mm deep, without obstructions, which might prevent the door from opening.
- Have a smooth connection between the opening and the chimney, with no ledges where soot might be trapped. The slope of the flue gather should be less than 30° to the vertical with a gap of 100 to 125mm between the fireback and throat lintel.

To work correctly, the ESSE 300 must form an absolutely airtight seal against the fireplace. So, if there is a rough surface (such as brick or stone) around the 'C' area, apply a skim of fire cement to smooth out the parts where the seal will be made.

Make sure the fireplace opening is level, and clear of dust and grit. Fit the soft fibre seal against the back of the stove using the double-sided tape supplied. Place the appliance on the hearth and push it fully into the fireplace so that the fibre seal is fully compressed.

Open the fire door. Remove the inner fittings, grate and ashpan. Mark the position of the fixing hole in the base of the ashpit. Remove the fire and drill at the marked point 35mm deep using a 6mm-masonry drill. Insert the alloy screwplug into the hole.

Push the appliance back into the fireplace opening. Insert the screw through the hole in the ashpit and screw it very firmly into the alloy plug. Put your hand into the chimney through the stove's flue outlet. Move the clamping bar into a vertical position. Hold it there while you tighten the clamping screw, located just above the fire opening. This will firmly pull the appliance against the fireplace. In a few cases, the threaded rod connecting the clamping screw to the clamping bar will be too long or short. If too long, it can be cut down using a junior hacksaw. If too short, longer lengths of M8 threaded rod can be obtained from hardware shops.

Replace the internal components and fit the throat plate as shown in the diagram (see next page).

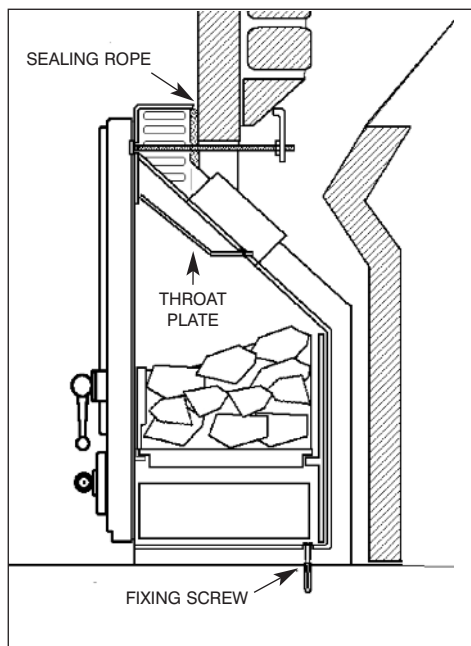

CHECK THE INSTALLATION !

It is imperative that:

- (1) the route for gases from the stove to the chimney terminal is completely airtight.*
- (2) It is possible to sweep the entire length of the flue- access doors may be required.*
- (3) The entire construction is of durable fireproof materials.*

LIVING WITH A 300

LIGHTING

If you're lighting the fire after a period of non-use, do check the chimney for blockages first! Empty the ashes. Place two or three firelighters close together, or screwed-up paper covered with dry sticks, at the back of the grate and light them. When they are burning well gently fill the fire very full, just up to the level of the top of the cast-iron liners, with dry fuel, close the door and set the air control to the 'high' position.

CONTROL

how fast the fire burns depends on how much air reaches the fuel. Use the operating tool to turn the spinwheel air control below the window anti-clockwise for highest output, or clockwise for 'low'. Fuels which give off large amounts of volatile gas (housecoal, lignite etc), may be more difficult to control.

ECONOMY

Surprisingly, best economy is achieved with the firebox very full and the air control set to 'low'. The fire will burn much more efficiently than if you use 'little and often' and will need less frequent refueling.

EMPTYING ASHES

Use the tool to open the door. Stir the fire with a poker and use the tool to lift out the ashpan. Remember to let ash cool before disposing in plastic sacks or dustbins. There is no need to empty every last speck, but ash should never be allowed to build up so that it comes into contact with the underside of the grate.

EXTENDED BURNING

Allow the fire to burn down to a low, hot firebed. Empty the ash and fully fill with hard

fuel such as anthracite or hard coke (smaller sizes are to be preferred). Set the air control to 'low' and your Esse can burn for up to twelve hours without attention.

CLEANING

Wipe the stove body with a slightly damp cloth when cool, don't use abrasives, metal polish or 'cream' cleansers as they can scratch the surface. Polished parts can be brightened using wire wool. With most fuels the window will require no cleaning other than an occasional wipe with a dry cloth. Simply operating the stove for a few minutes at high output will usually burn-off any deposits left by tarry or wet fuels. Severe stains can be removed with a proprietary cleaner available from stove shops. After a period of use tiny hairline cracks may appear on the window, this is not a fault, but is characteristic of the toughest and most heat-resistant material currently available.

KEEPING THE WINDOW CLEAN

Extended use at low output or with damp fuel can stain on the window. Reduce the risk of staining by using only very dry fuel. With some fuels, you may find it advantageous to leave the door slightly open for the first few minutes after refueling, while the smoke and tars burn away.

OPENING THE DOOR

The ESSE 300 is designed to be operated only with the door closed. Open the door slowly when refueling or de-ashing to minimise fumes emission into the room.

FUELS

In certain areas you are required by law to burn smokeless fuels. Different fuels have very different burning characteristics, and will perform differently with different chimneys and air supply situations. There is no 'perfect' fuel for every situation, so we strongly recommend that you try a selection of fuels (or mixtures) to find which suits you best.

WOOD (Not smokeless)

When wood is cut down its cells are full of water. Burning such wet or 'green' wood wastes heat in making steam and produces flammable, acidic tars which will cling to, and can damage, your stove and chimney. Logs should be dried for at least a year (outside under a tarpaulin

will do). When dry enough to burn, the ends will split. The fine, white residue produced when wood burns is not ash, but the remains of cell walls which can burn if kept hot enough, so don't de-ash the fire until absolutely necessary.

HOUSECOAL (or BITUMINOUS COAL) (Not smokeless)

Is raw, natural coal. Inexpensive, easy to light and low in ash, it burns with great heat and an attractive flame. However, it makes lots of tarry smoke which will stain the window and large volumes of flammable gas which sometimes make it difficult to control. Despite its low cost, it rarely represents value for money.

ANTHRACITE and WELSH DRY STEAM COAL (Smokeless)

Are natural hard, shiny forms of coal. Though difficult to light, they burn with great heat and last a long time. Choose the 'small nuts' size.

PEAT (Legally smokeless in certain areas)

is semi-decomposed woody material found naturally. The nearly black moorland or bog peat should be dried and treated as for wood.

LIGNITE (Not smokeless)

is a natural mineral, between peat and coal. It lights easily and burns well, though some varieties produce excessive ash

BRIQUETTES

Are compressed blocks of fuel, generally able to burn for long periods and remarkable for their consistency. 'Homefire' and 'Phurnacite' are smokeless types while other brands are made from lignite, peat or housecoal.

PETROLEUM COKE

Sold as 'Petcoke', 'Longbeach' and under various proprietary names, is made from oil waste. Easy to light and to control, its exceptional heat and lack of protective ash mean that it is **MUST NOT** be used unless mixed with another fuel. Grate and firebar life will be drastically reduced when using petroleum coke

HOUSEHOLD WASTES

Some plastics give off toxic fumes when burned and remember that batteries and aerosols explode! The Esse 300 is not an incinerator, so only ever use the recommended fuels and **NEVER** use liquid fuels in any form

in the firebox, then this is probably because too little air has been reaching it, try leaving the air control open a little more. Check that the door seals are sound and that there are no cracks or gaps anywhere in the flue. For longest burning, we recommend hard fuels such as anthracite.

- **SMOKE COMING INTO ROOM.** Fumes are poisonous- smoke emission must not be tolerated, causes might be:
 - *INADEQUATE SEALS:* Check that the appliance is fully sealed against the fireplace. Even the tiniest crack or gap can spoil the draught.
 - *UNSUITABLE, BLOCKED OR UN-SWEPT CHIMNEY:* The first requirement for correct operation is a sound chimney. Check the requirements earlier in this document and in any case of doubt have the chimney professionally swept.
 - *POOR AIR SUPPLY:* Lack of air to the fire will cause smoking and poor performance.

Air supply problems may be worse in certain wind conditions (often incorrectly ascribed to 'downdraught', which is in fact very rare), where air can be sucked out of the room. The answer is to fit an air vent, as near to the fire as possible, facing into the usual wind direction.

- *DOWN DRAUGHT:* Wind can blow down a chimney if there is something higher nearby such as a tree, hill or high building. Fitting an anti-downdraught cowl to the chimney top can cure this. Types, which cannot be swept through, are not recommended.
- **POOR CHIMNEY DRAUGHT**
In circumstances of poor chimney draught causing fume emission, which cannot be remedied otherwise, the ESSE 300 may be operated with the throat plate permanently removed, though this will somewhat reduce its efficiency

PROBLEMS

Problems like those listed here are due to some difficulty with the installation, chimney or fuels, so please check back through this leaflet carefully.

- **POOR HEAT OUTPUT:** The Esse 300 is sufficient to heat a typical room of up to 75m. The actual size depends on the insulation and air-change ratio of the room. To attempt to heat a larger room will result in excessive fuel consumption. Use only the recommended fuels. If necessary seek specialist advice.
- **LACK OF CONTROLLABILITY:** Some fuels

give off lots of very flammable gas when they get hot. The 300's 'airwash' sends air into these gasses to ensure that they burn off safely. This means that some fuels, especially some types of wood and housecoal, may burn excessively until the gases have been used up. You can reduce this effect by making sure that the fire is set to 'low' for a while before refueling and checking that the door seals fully.

- **DIFFICULTY BURNING FOR EXTENDED PERIODS.** If the fire goes out with fuel still

MAINTENANCE

- **MONTHLY**
Check that the door seals are undamaged, and that the flue is clear and unblocked.
- **ANNUALLY SWEEP THE CHIMNEY**
The entire length of the chimney from stove to outlet should be swept annually, or more often if smoky fuels are used.
- **REFURBISHMENT**
Should the stove body become scratched or dull, repaint it only with heat resistant paint sold for the purpose and only when the fire is completely cold.

- **NEW PARTS**
The Esse 300 has been extensively tested for safety - please don't try to modify it and always make sure to obtain genuine spare parts.
The 300 is fully guaranteed (excluding wearable components) for one year from the date of purchase, in addition to your statutory rights.