

GUARANTEE

08/08

CONDITIONS OF GUARANTEE

Your ESSE stove is guaranteed against defects arising from faulty manufacture for two years subject to the following express conditions. Failure to comply with these conditions will invalidate the guarantee.

- Your ESSE dealer or a suitably qualified engineer must install the stove. Upon installation the receipt must be kept as proof of purchase.
- The guarantee is one year from date of purchase.
- The guarantee does not cover parts deemed to be replaceable in the normal usage of the stove. These parts are listed below:

All Models: glass panels, rope seals, glass seals.

Solid Fuel Models: bottom grate or firebars, ashpan, firebricks, cast iron liners, riddling lever, baffle plate, log guard.

Natural Gas or L.P.G Models: Ceramic coals and matrix, TTB switch.

Boiler Models: boilers are guaranteed against weld failure. Appropriate precautions must be taken to prevent internal corrosion.

INTERMITTENT USE OF YOUR STOVE - ENAMEL STOVES ONLY

In the event of intermittent use and prolonged shutdown, it should be noted that in some circumstances enamel might be displaced due to ingress of damp. Whilst this is rare, it is most likely to occur in situations where the unused stove remains in an unheated property. There is a layer (known as the groundcoat) between the vitreous enamel surface and the cast iron. Groundcoat is porous and if exposed (e.g. after a chip in the vitreous enamel coat), may allow damp to penetrate behind the vitreous enamel and spread through the groundcoat. Surface oxidation of the cast iron may thereafter occur, causing the vitreous enamel coating to fall off. Such damage will not be covered by your warranty. We recommend that a light coating of petroleum jelly be applied to any damaged areas when the stove is not in use to help to keep out the damp.

HOW TO PROCEED WITH A COMPLAINT

If you have cause for dissatisfaction with your stove, you should first contact your ESSE dealer who will, bring your concerns to our attention. We will assess the nature of the complaint and either send replacements parts for your dealer to fit, or nominate a regional engineer to inspect the appliance and carry out any remedial work that may be necessary. If the fault is not actually due to faulty manufacture but some other cause i.e. misuse, failure to install correctly, or failure to service at regular intervals, a charge will be made to cover the cost of the visit and any new parts required.



ESSE Engineering Limited, Ouzledale Foundry, Long Ing, Barnoldswick, Lancashire BB18 6BN
Tel: 01282 813235 Fax: 01282 816876 Website: <http://www.esse.com>

100/200/700

MULTI-FUEL STOVES

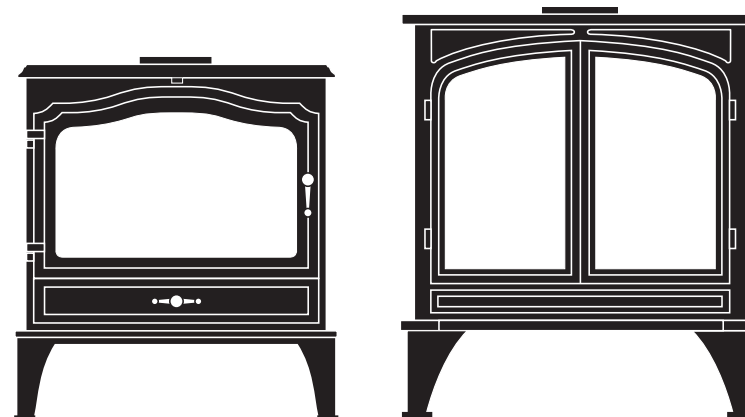

INSTALLATION & USER INSTRUCTIONS

(TO BE LEFT WITH THE CUSTOMER)

UK & Ireland



ESSE Engineering Limited, Ouzledale Foundry, Long Ing, Barnoldswick, Lancashire BB18 6BN
Tel: 01282 813235 Fax: 01282 816876 Website: <http://www.esse.com>

GB IE

CONTENTS

General Safety Notes	Page 2	Operating Instructions	Page 8
Chimney & Flue	Page 3	Woodburning	Page 8
Flue Draught	Page 5	Solid Mineral Fuel Burning	Page 10
Dimensions & Clearances	Page 6	Maintenance	Page 11
Installing the Stove	Page 6	Guarantee	Page 12

GENERAL SAFETY NOTES



- Properly installed, operated and maintained, this appliance will not emit fumes into the dwelling. However occasional fumes from de-ashing and re-fuelling may occur. Persistent fume emission is potentially dangerous and must not be tolerated. If fume emission does persist, open doors and windows to ventilate the room. Let the fire burn out or eject and safely dispose of fuel from the appliance. Once the fire is cold, check the flue and chimney for blockages and clean if required. Do not attempt to relight the fire until the cause of the fume emission has been identified and corrected. Seek expert advice if necessary.
- Do not fit an extractor fan in the same room as the appliance.
- An adequate air supply for combustion and ventilation is essential. Air openings provided for this purpose must not be restricted.
- It is important that flue ways are cleaned frequently and the chimney swept regularly. Also the stove must be maintained in good mechanical order. Regular sweeping means at least once per year for smokeless fuel and a minimum of twice per year for other fuels.
- If the chimney was previously used for an open fire, it is possible that the higher flue gas temperatures generated by the stove may loosen deposits that were firmly adhering to the inner surface of the chimney and cause blockage of the fluepipe. We recommend that in such a situation a second sweeping of the chimney should be carried out within one month of regular use of the stove after installation. Also, lock or remove any existing dampers in the flueway.
- Should it be likely that children, aged or infirm people approach the fire, then a fireguard should be fitted.
- Avoid the use of aerosol sprays in the vicinity of the stove when it is in operation.
- The installer has a responsibility under the Health and Safety at Work Act 1974 to provide for the safety of persons carrying out the installation. Attention is drawn to the fact that fire cement is caustic and hands must be washed thoroughly after use. The appliance is heavy and care must be taken during handling. Although the appliance does not contain asbestos products, it is possible that asbestos may be disturbed in existing installations and every precaution must be taken.

- These instructions give a guide for the installation of the appliance but in no way absolves the installer from responsibilities to confirm to British Standards, in particular BS8303 and BS6461, relating to the installation of solid fuel appliances. The installation should also comply with local Building Regulations and Local Authority Bye-Laws.
- The stove must be placed at least 40cm away from any combustible materials. If necessary, any adjoining walls should be protected from the effects of heat.

CHIMNEY & FLUE

The successful operation of these appliances relies on the adequate performance of the chimney to which it is connected. The chimney must:

- Have an internal cross section of no less than 320 cm.sq (200mm Dia.). (If a flue liner is used it should be 5" diameter, for 100 and 200 stoves, 6" diameter for the 700 stove and suitable for solid fuel).
- Be a minimum 4.6m high from hearth level to pot.
- Be terminated at least 1m above roof level so that the chimney does not terminate in a pressure zone. See Fig.2
- Be free from cracks, severe bends, voids, and obstructions.
- Be connected to this one appliance only.
- New chimneys must be built in accordance with local building regulations.
- Existing chimneys must be tested in accordance with HETAS requirements.
- If the stove is installed as a freestanding appliance, it should not support any part of the chimney.
- Voids in the chimney should be avoided, as these will prevent a steady flue draught.
- The stove flue pipe should pass beyond the narrowing of the chimney. See Fig.1
- Consideration should be given to falling soot. For rear outlet stoves it may be necessary to provide a soot catchment area in the flue pipe so that soot does not settle in the path of the flue gases. The optional rear flue box attachment available from ESSE has a detachable base that allows for fallen soot to be removed. See Fig.1.
- A flue/chimney access point may also be required so that the state of the chimney can be checked and any fallen soot removed.
- External flues must be insulated to prevent heat loss.

Fig.1 - Ideal Flue Connections. Optional rear flue box attachment is for use with the 100 / 200 stoves only

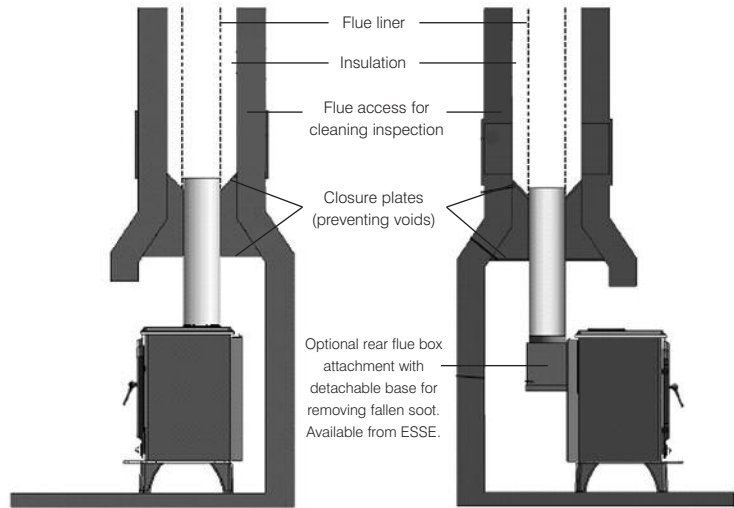
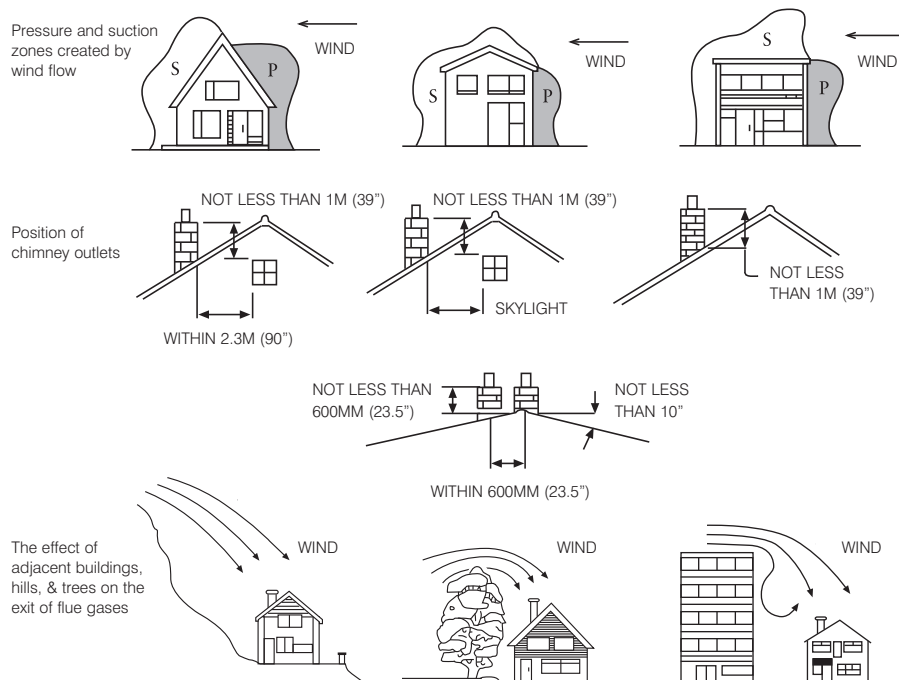

Fig.2 - Chimney and Flue Performance



FLUE DRAUGHT

The chimney can be checked, before the stove is installed, with a smoke match. If the chimney doesn't pull the smoke it may suggest the chimney needs attention (see the Flue Diagnosis Table, below).

Measurements

The flue draught test hole must be drilled in the flue pipe as close to the stove as possible and before any flue draught stabiliser.

Note: This test is only a guide as an apparently poor flue may improve once the stove is installed, lit and the flue is warmed. If, once the stove is installed, there is any doubt that the chimney is providing an adequate draught, a flue draught reading can be taken with the stove lit. Two flue draught readings should be taken, one with the stove at minimum firing rate and one at maximum firing rate.

Minimum

The stove should be lit and allowed to warm the flue thoroughly. The air controls can then be set so that the stove burns on a low setting. Allow the burning rate to become steady. The flue draught reading should now be taken with the primary air intake closed and the airwash control fully open.

Maximum

The primary air intake can now be opened to allow the stove to burn at maximum rate. Give the stove some time for the burning rate to become steady and then close the primary air intake, make sure the airwash control is fully open and take a flue draught reading immediately.

Ideally, the flue draught readings should range between 1mm wg and 2.5mm wg. Any readings significantly outside this range may indicate the need for remedial action.

Low flue draught symptoms: difficult to light and smoke coming into the room.

Cause	Remedy
Cold chimney	Line the chimney
Chimney too short	Extend the chimney
Down draught	Relocate/extend chimney terminal. Fit an anti down draught cowl
Chimney diameter too large	Line the chimney
Chimney obstruction	Clear/sweep the chimney
Restricted air supply	Check for competing draughts (other chimneys, extractor hoods/fans). Fit an air vent if the room is sealed.

High flue draught symptoms: fire difficult to control, fuel will not last, stove too hot, stove damage, chimney fire.

Cause	Remedy
External wind conditions combined with chimney terminal	Fit stabilizer cowl. Fit flue draught stabilizer.

FLUE STABILIZER

A flue stabilizer can be fitted to reduce the draught through the stove if the flue draught is too high.

The flue stabilizer should be:

- fitted in the same room as the stove
- the same size as the flue pipe
- fitted no closer than 700mm to the flue outlet of the appliance.

DIMENSIONS & CLEARANCES (all measurements are in mm)

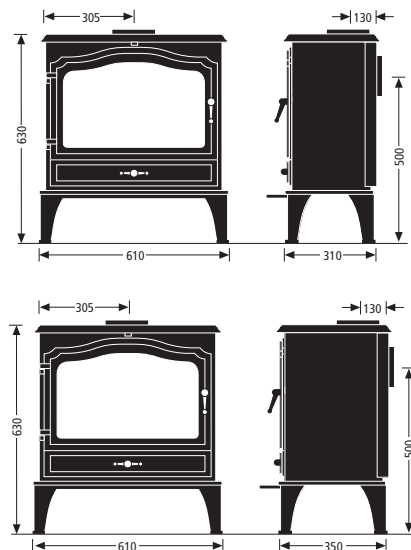
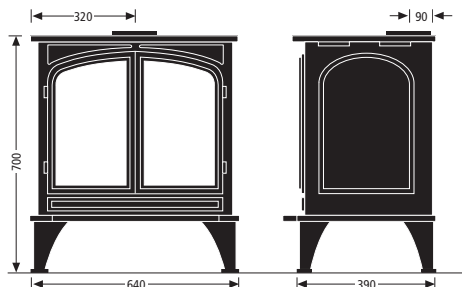

Fig.3

Clearances from combustibles:

A: Sides 400 **B:** Top 450 **C:** Rear 400 **D:** Front 305



INSTALLING THE STOVE

Positioning

The overall dimensions of these stoves are shown in Fig.3. Fig.3 shows recommended distances between the stove and surrounding combustible materials. As a rule, any surrounding combustible material should not exceed 80°C. There should be sufficient space around the stove for service work.

Hearth

The construction of the hearth must conform to Building Regulations, must be firm, non-combustible and capable of supporting the stove.

Flue Connection - 100 & 200 Stoves

The flue pipe used to connect the stove to the chimney is 5" (125mm) in diameter. The stove is supplied ready for top flue connection. To change to rear connection the flue blanking plug supplied with the stove is used to block the top flue outlet. The blanking plug in the rear flue connection must then be removed (to access the bolts attaching the rear flue connection the convector panel must first be removed), see Fig.4. A rear flue box attachment is also available from ESSE that allows the stove to be installed further out of any building recess. Fig.1 shows suitable flue connections.

Flue Connection - 700 Stove

The flue pipe used to connect the stove to the chimney is 5" (125mm) in diameter. The stove is supplied ready for top flue connection. Fig.1 (left hand side illustration only) shows suitable flue connections.

Important Installation Notes:

1. The installation must allow for adequate chimney sweeping.
2. Avoid using bends greater than 45° to the vertical. All flue pipe sections should be as close to vertical as possible.
3. All joints in the flue system must be effectively sealed.
4. All flue sockets must face upwards.

On completing the installation, check that all the internal components of the stove are positioned correctly.

Check - ash pan, iron grate, baffle, side and back bricks, coal bar.

Fig.4 - Arranging the flue plug for top or rear outlet for 100 / 200 Stoves

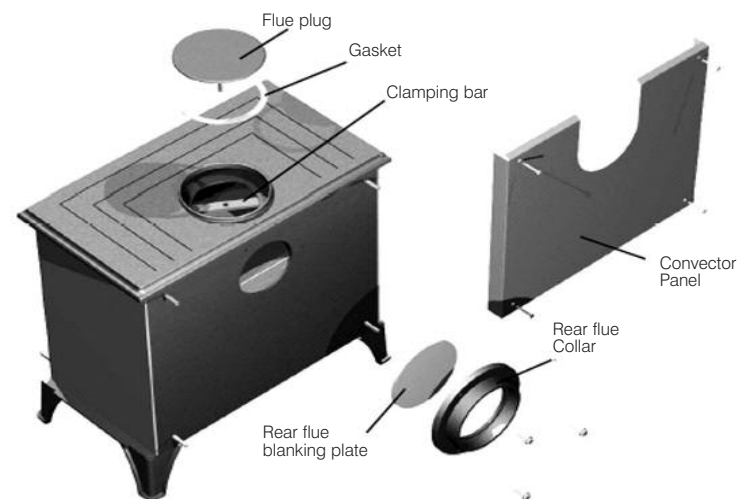

Fig.5 - Using the stove mitt

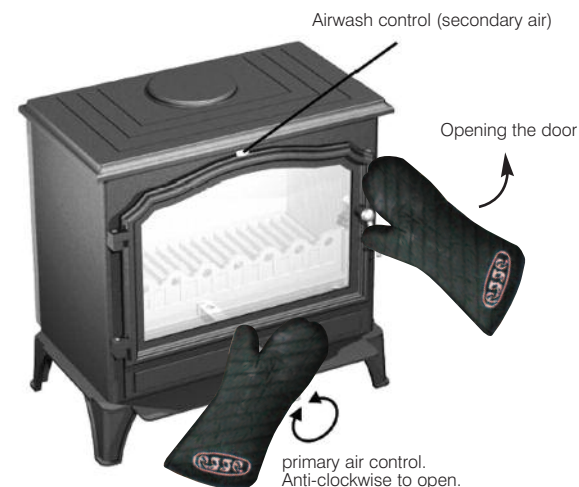

Fig.6a - 700 Stove

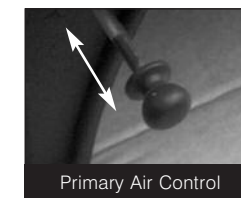

Fig.6b - 700 Stove



OPERATING INSTRUCTIONS

Your Stove

Fig.5, 6a & 6b shows the stove and its controls.

Additional loose parts supplied inside your stove include:

- A stove mitt is provided - for removing the ash pan, adjusting the primary air control, adjusting the air wash control, and operating the door handle. Fig.5 shows how the stove mitt is used.
- A flue blanking plug to blank the top flue outlet if the rear flue outlet is to be used (100 / 200 Stoves only).

WOODBURNING

Lighting & Controlling the Fire

Before lighting the fire for the first time ensure that the baffle, the side and back bricks and all the internal components are in position.

Open the air wash control and the primary air control fully. Place some tightly rolled paper on top of some crumpled paper on the base towards the back of the stove. On top of this, place some small pieces of wood. Light the crumpled paper and close the door. Once the fire becomes established add some larger pieces of wood. As the stove comes up to temperature close the spinner. The burning rate of the stove can now be regulated by the rate at which fuel is added and by adjusting the air wash control.

With the above in mind it is plain to see that the stove should ideally be run with the primary air inlet closed and the air wash control open whenever possible. Another advantage of running the stove with the air wash open is that the air being drawn into the stove travels across the glass forming an air barrier between the glass and the fire bed helping to prevent smoke particles sticking to the glass. If the fire dies down too low, opening the primary air control for a short period will revive it.

700 Stove

When burning wood, start a small fire with firelighters and small, dry kindling. Both the Primary and Secondary air should be fully open. It may be necessary to crack open the doors to allow additional air through the stove until the fire is established. Gradually add further logs and close the Primary air. The fire may now be controlled with the Secondary air control.

Note: Wood burns most efficiently when the air for combustion is supplied from above the fire bed rather than below. The air supplied above the fire bed provides the oxygen necessary for the volatile gases (smoke), given off by the wood as it heats, to combust. This ensures that the gases are burnt and used to heat the stove instead of being wasted up the chimney or condensing and forming tarry deposits inside the stove, in the flue or on the stove glass. Running the stove with the primary air control open and the air wash control closed will provide oxygen for the wood to burn on the fire bed but will not provide air for the volatile gases above the fire bed to combust resulting in a smoky inefficient fire.

Correct running temperatures for wood burning

To get the best results from your stove it is recommended that a wood stove thermometer (available from your stove dealer) be fitted to the flue pipe above the stove, at eye level if possible. The figures below show the recommended temperature of the flue gases:

115 °C - 245°C (240°F – 475°F)

The flue gases should be in this temperature band for the safest, most efficient and most economical operation of your stove.

Below 115°C (240°F)

This is below the condensation point of wood gases and may cause the build up of tar in the chimney, dirty the stove glass and result in the inefficient burning of fuel.

Above 245 °C (475°F)

Too hot. Heat will be wasted up the chimney. Excess heat may damage the stove or ignite an existing accumulation of tar resulting in a chimney fire.

Extended burning

Loading a large amount of wood into the stove all at once will reduce the temperature inside the stove. If the temperature is too low, the gases given off from the wood will be too low to combust resulting in a lot of smoke covering the inside of the stove, including the glass, with soot. To combat this problem it is a good idea to increase the temperature of the stove before loading by further opening the air inlets. Load the wood and leave the air controls open until the moisture is driven out of the wood and the stove is back up to an efficient operating temperature. The air inlets can then be reduced to hold the temperature of the stove. Loading the stove little and often will help keep the stove temperature steady. When loading wood, make sure that the end grain of the wood in the stove is pointing away from the glass otherwise the moisture and gases coming from the end grain of the wood will dirty the glass.

Note: The above text should be used as a guide only. The ideal operation of your stove depends on a number of factors, which vary with each installation, and so gaining experience operating your stove is the only way to learn its best operation.

Types of Wood for Fuel

For best results use well seasoned hardwood such as Oak, Ash, or Beech. Allow wood to dry out under cover in well-ventilated conditions for at least twelve months. Wood is ready for burning when radial cracks appear in the end of the logs. Burning wood that is not seasoned will result in tar being deposited in the stove, on the glass and in the flueways. This build up of tar is a hazard and if it ignites may cause a chimney fire. Resinous softwood burns well and gives a high output for short periods but is not as efficient and does not last as long as hardwood.

Peat

Peat is a fuel conveniently available in some areas and should be burned in the same manner as wood.

SOLID MINERAL FUEL BURNING

Note: 200 Stoves Only 1) Remove cast iron grate 2) Remove the steel grate 3) Replace the cast iron grate.

Note: 700 Stove Only 1) Remove steel plate on top of grate.

Lighting and Controlling the Fire

Before lighting the fire for the first time ensure that the baffle, and the side and back bricks are in position. Burning without either will result in the stove castings overheating and being damaged.

Open the air wash control and the primary air control fully. Place some tightly rolled paper on top of some crumpled paper on the base towards the back of the stove. On top of this, place some small pieces of wood and on top of that a few small pieces of mineral fuel. Light the crumpled paper and close the door. Once the fire becomes established and the fuel is burning, more fuel can be added. When the stove is hot and the fuel is no longer producing smoke, the air wash control can be reduced. The burning rate of the fire can now be controlled with the spinner. As air from the spinner flows up through the grate it will cool the grate bars preventing them from overheating and becoming damaged. Reducing the spinner air inlet and introducing air only from the air wash will allow the fuel to burn but the grate will not be cooled resulting in damage to the grate bars. When controlling the fire, the spinner should be altered gradually. Reducing the primary air dramatically and all at once on a hot stove will cause the fuel to clinker and will result in a build up of gases and smoke which could ignite with a bang the moment air is reintroduced.

700 Stove

When burning a solid mineral fuel, start with a small fire of dry wood and firelighters. Once burning well, add a little solid fuel and keep adding to establish the desired firebed. Start with the primary air control fully open, and once the bed of coals are burning enough, regulate the fire by closing the Primary air to the required setting.

Initially the Secondary air should be fully open, but once the fire is burning cleanly, this can be closed and remain closed.

Extended Burning

Before adding a large amount of fuel, the grate should be de-ashed and the ash pan emptied. Add the fuel sloping it from the front coal bar up to the back of the stove to the level of the top of the back brick. Open the primary air inlet and let the fire burn for a period on high rate in order to get the stove back up to temperature and drive off the moisture and gases in the fuel. If a lot of smoke is produced on reloading, the air wash control can be opened further to keep the smoke back from the glass. As the fire gets back up to temperature, reduce the air wash control and reduce the primary air inlet to suit the burning rate. The exact setting of the air controls depends on a number of variables including; the flue draught, the fuel used and the installation and so the best settings for your stove can only be learned by experience.

Ash Removal

The level of ash should not be allowed to build up to the level of the grate. If the level of ash becomes too high the air through the grate will become restricted causing the grate bars to overheat and preventing the fuel from burning efficiently.

MAINTENANCE

Grate Bars

The grate bars in the centre of the stove will wear more quickly than the ones at the edges. To ensure even wear, swap the positions of the grate bars occasionally.

Mineral Fuels

Ordinary bituminous house coal is not recommended and must not be burned in smoke control areas. Burning bituminous house coal will result in a sooty stove and chimney, and the stove glass will require cleaning regularly. There are numerous natural anthracites and manufactured smokeless fuels that will burn cleanly and have more reliable burning characteristics. A list of these fuels and their suitability is produced by HETAS (www.hetas.co.uk). Consult your local fuel merchant to find out what is available in your area. Petro-coke should not be used as it burns very hot and may damage the stove castings.

Cleaning the Stove

The stove should only be cleaned when it is cold. The exterior can be dusted with a firm brush. Do not use a cloth, as this will drag on the paint finish leaving lint on the surface. From time to time it may be necessary to renovate the exterior by repainting. High temperature stove paints in aerosol form are available from your stove dealer. Do not use this form of paint until the stove is cold and always read the instructions on the container before starting to paint. The door glass is made of a special heat resisting ceramic and may be cleaned when cold with proprietary glass cleaning liquids and a dry cloth.

Shutting Down the Stove (Long Term)

The following procedure should be followed if the stove is not to be used for a long period, summertime for instance. Remove all the ashes from the grate and ash pan and use a vacuum cleaner nozzle to clean ash from the base of the stove. Remove the baffle plate and brush the flue ways. Close the door and open the air inlets fully. This action will allow air circulation through the flue ways and help to avoid corrosion and condensation.