

Cooker Model:	_____
Serial Number:	_____
Colour:	_____

GUARANTEE

CONDITIONS OF GUARANTEE

Your **esse** cooker is guaranteed against defects arising from faulty manufacture for three years, subject to the following express conditions:

- This cooker must be commissioned by your esse Dealer (or an authorised OFTEC engineer) upon installation. The details must be recorded on the Commissioning card and registered with esse by returning the completed card. The guarantee period commences upon delivery of the cooker (subject to receipt of the correctly completed card).
- The cooker has been used for normal domestic purposes only, and in accordance with the manufacturer's instructions.
- The cooker is serviced annually by the esse Dealer or authorised OFTEC engineer, and the Service record completed. The cooker must not be serviced, maintained, repaired, taken apart, or tampered with by any person not authorised by us.
- Any cooker or defective part replaced shall become the Company's property.

EXCLUSIONS

This guarantee does not cover:

- Damage or calls resulting from transportation, improper use or neglect.
- Parts deemed to be replaceable in the normal usage of the cooker. These parts are listed herewith: VAPORISING MODELS; burner pot, burner rings, oil control valve, oven thermostat, transformer, glow plug.
- Enamel damage; the vitreous coating on your cooker is in effect an extremely thin layer of glass and as such displays all the characteristics of glass. It can easily be damaged by impact, or by spillage of cold liquids onto a hot surface. Such damage cannot be covered under this guarantee. (See also intermittent use of your cooker, below).
- Boilers; guaranteed against weld failure. Appropriate precautions must be taken to prevent internal corrosion. This guarantee is personal to the original purchaser and is non-transferable.

INTERMITTANT USE OF YOUR COOKER

In the event of intermittent use and prolonged shutdown, it should be noted that in some circumstances enamel may be displaced due to ingress of damp. Whilst this is rare, it is most likely to occur in situations where the unused cooker remains in an unheated property. There is a layer (known as the groundcoat) between the vitreous enamel surface and the cast iron. Groundcoat is porous and if exposed (e.g. after a chip in the vitreous enamel coat), may allow damp to penetrate behind the vitreous enamel and spread through the groundcoat. Surface oxidation of the cast iron may thereafter occur, causing the vitreous enamel to fall off. Such damage will not be covered by your warranty. We recommend that a light coating of petroleum jelly be applied to any damaged areas when the cooker is not in use to help keep out the damp, in addition to following the instructions in your Operating manual.

CUSTOMER CARE

In the event you should require spare parts, please order through your esse dealer.

Should you have cause for dissatisfaction with your cooker, you should contact your esse dealer who will, in most instances, be able to offer you immediate assistance. You will be required to give the following details:

- Your name, address and postcode.
- Your telephone/contact details.
- Clear and concise details of the fault.
- Model and serial number of the cooker (found on the data plate on the inside panel of the control door).
- Purchase date (Please note that a valid purchase receipt or guarantee documentation is required for in-guarantee service calls).

We will then check that we have an accurately completed warranty card, if not then any work carried out will be charged. We will assess the nature of the complaint and either send replacement parts for your dealer to fit, send an engineer to inspect & report, or send an engineer to remedy. If the fault is not actually due to faulty workmanship but some other cause such as misuse or failure to install correctly, a charge will be made to cover the cost of the visit and any new parts required, even during the warranty period. Home visits are made between 08.30 – 17.00hrs Monday to Friday, and are arranged for either a morning or afternoon appointment.

OIL FIRED COOKERS

OPERATING INSTRUCTIONS

MODELS: ON & OD



Ouzledale Foundry Co. Limited, Long Ing, Barnoldswick, Lancashire BB18 6BN

Tel: 01282 813235 Fax: 01282 816876 Email: enquiries@esse.com Website: <http://www.esse.com>

INTRODUCTION

We are pleased that you have chosen an ESSE cooker. We would ask that you read the following operating instructions very carefully.

Correctly installed and operated your ESSE cooker will give satisfactory service for many years.

We feel certain that you will enjoy the warmth and comfort of your ESSE cooker and, perhaps more importantly, you will more than enjoy the superb quality of the cooking.

Contents	
Your Cooker	Page 3
Tools & Accessories	Page 3
Before Using Your Cooker	Page 4
The Burner	Page 4
The Hotplate	Page 7
The Ovens	Page 8
Temperature Settings	Page 8
Cleaning and Maintenance	Page 9
Guarantee	Page 12

YOUR COOKER

Model 'ON' has no boiler, Model 'OD' has a boiler for domestic hot water only.

Your cooker is a combination appliance providing hotplate, fast and slow ovens and where applicable, hot water service. A single burner is located under the left hand end of the hotplate.

There are two hinged stainless steel covers to conserve heat losses from the hotplate when it is not in use.

A direct flue damper is fitted in the bottom of the fluebox and is in the open position when lever is pointing to the rear of the cooker. This is used on initial light up and also gives a cooler oven temperature when open.

Tools and Accessories

The following items are supplied with your ESSE cooker:

Decarbonising tool - For removing carbon deposits from the oil entry tube of the burner.

Universal tool and burner scraper - For scraping the burner pot.

Small wire brush - Cleaning of the burner pot. Do not use on the enamel finish of the cooker.

Kindler - For lighting the burner.

Hotplate lifting tools - For lifting off the hotplate.

Oven Accessories - Roasting Tin, two Wire Shelves and Baking Tray.



Store these in the Accessory Box (Fig 2)

Your Cooker - Fig.1

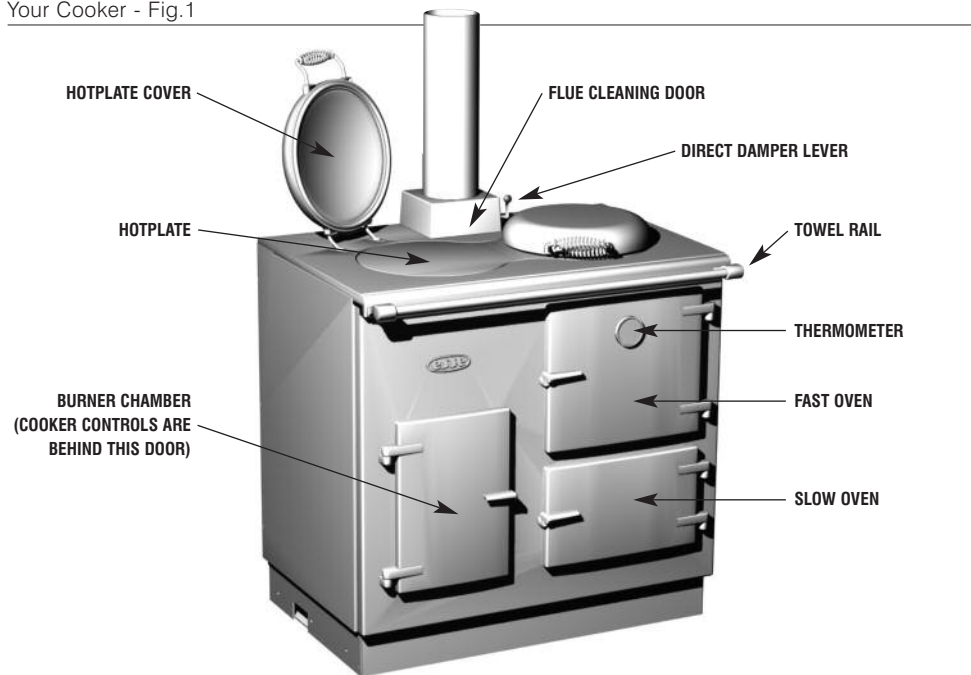

BEFORE USING YOUR COOKER

Check that the plastic protection coating has been removed from each hotplate cover, and from the inside of the doors. This should have been done during installation but if the plastic has been left on it will melt on firing the cooker and cause damage to the linings.

The hotplate surface should be wiped with a dishcloth or similar, which has been soaked with hot water and a detergent liquid. Finally dry off the

THE BURNER

The Oil Burner and Method of Control

The burner fitted to your cooker consists of a rectangular stainless steel pot containing a catalyser - (Fig. 3.) Heat control is affected by manually setting the control knob, located behind the burner chamber door.

Important Notes to Remember

The burner used in this cooker vapourises the fuel almost immediately as it enters the burner pot;

hotplate with an absorbent material.

Note: FUEL - Your cooker may have been installed for use on either Commercial Kerosene, 28 sec to BS 2869: 1983 Class C2 or 35 sec 'Heating Oil' (Diesel). You must use the correct grade of oil. Check the data plate on the inside of the Accessory Box (Fig. 2).

If in doubt ask your installer.

when the cooker is hot there should be no significant amount of oil in the base of the burner pot.

When lighting the burner, the lighting instructions must be strictly adhered to.

Lighting the Burner

WARNING

Should the burner go out for any reason it must not be re-lit when it is hot, allow it to cool down first.

Should the burner go out whilst the oil control knob is set at any position other than OFF, oil will continue to flow into the burner pot until the trip mechanism on the oil control valve automatically stops the flow.

This situation is known as a FLOODED BURNER and must be dealt with in the following manner:-

Do not attempt to re-light or uncontrollable combustion may occur. Remove the hotplate, and burner catalyser. Swab out all oil from the burner pot, by using a waste rag or absorbent tissue. Replace burner parts and hotplate, then re-light burner as normal.

Open the direct damper by pointing the lever to the rear of the cooker. If lighting for the first time or the oil supply has previously run dry, lift and release the arming lever (Fig. 5)

Models not fitted with electric ignition - Open the burner chamber door and remove the burner lighting plug (Fig. 2). Insert the end of the kindler into the lighting port and push kindler down to the bottom of the pot. Turn the grey control knob to the highest setting and allow a few seconds for the kindler to absorb fuel then turn the grey control knob to the OFF position. Remove the kindler, light and re-insert into the pot. Turn the grey control knob to the highest setting (Fig 4)

When the fuel in the pot is seen to be well alight, turn the control knob to the second setting.

After about ten minutes, remove the kindler, check the fuel is alight, replace the lighting plug and close the burner chamber door. Allow the kindler to cool, then store in the Accessory Box.

Burner Chamber - Fig.2

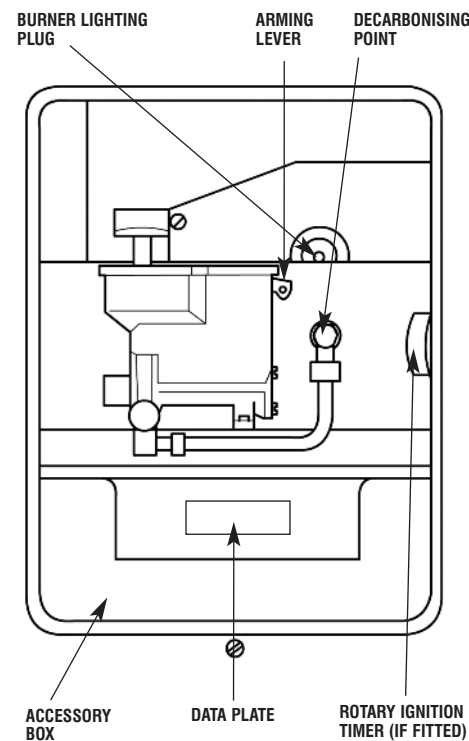

Rectangular Burner Pot - Fig.3

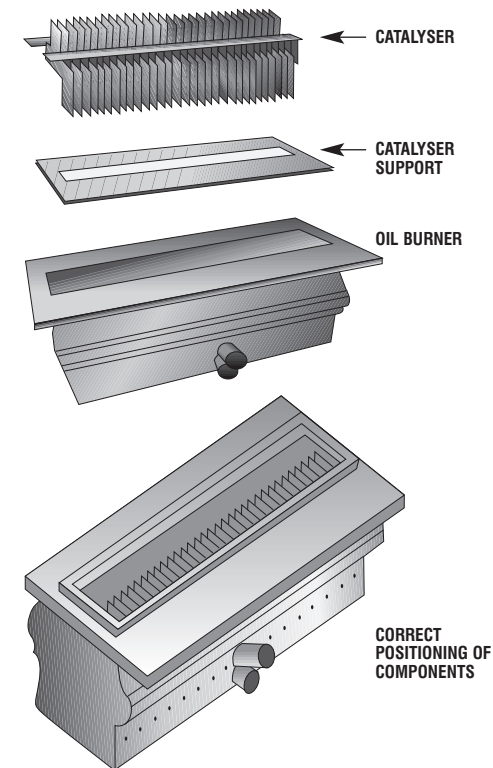

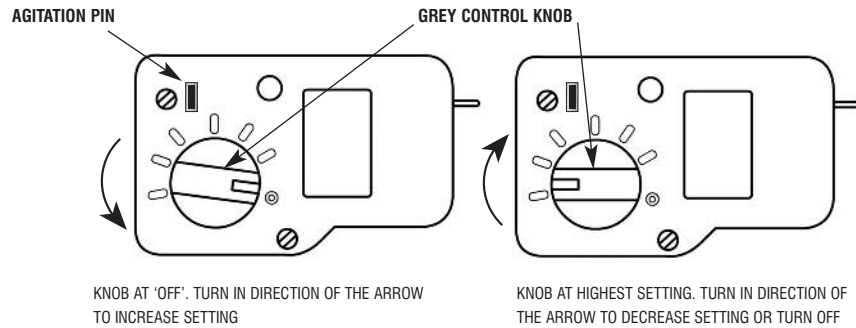

Increase the grey control knob setting as required, allowing at least ten minutes between each alteration, so that cooker and chimney can heat up gradually.

Models fitted with electric ignition -Turn the grey control knob to the second setting. Turn the rotary ignition timer fully clockwise (Fig. 2), the red ignition neon should light. If it does not light check that the cooker electrical supply is plugged in. The timer will operate for approximately two minutes by which time the stove should be alight.

Increase the grey control knob setting as required, allowing at least ten minutes between each alteration so that the cooker and chimney can heat up gradually.

Operating The Burner (Fig. 4)

The setting positions are **OFF** ('O') and the six settings round to the highest rate.

The knob locks in the **OFF** position and requires firm pressure to move from **OFF** to the first setting. Over the remaining settings the knob turns smoothly.

The setting will depend on the use to which the cooker is being put and the individual setting for particular use will be determined only by experience.

For low fire running, the first setting may be used.

To Extinguish the Burner

Turn the control knob to **OFF**, open the direct damper and allow the flame to gradually die down and to go out as oil in the pot is used up.

For lengthy periods of shut down, for example during holidays, turn the burner control to **OFF** as above and shut the valve on the supply line from the oil storage tank.

IMPORTANT

Do not tamper with the oil control valve. refer to the 'intermittent use of your cooker' section of the guarantee.

THE HOTPLATE

The hotplate is surface ground and intended for use with machined base utensils. As heat passes from the hot-plate to utensil almost directly by conduction, good contact is essential and a thin bottomed utensil will result in poor heating performance, especially if the bottom is uneven.

It is important to use pots and pans that have a ground base and are flat-bottomed on the hotplate.

Cookware made of stainless steel, cast iron, aluminium, glass and earthenware is suitable for your ESSE.

The hottest part of the hotplate is the left hand end while the area over the oven is cooler. Quick boil on the former and then transfer for simmering on the latter.

For deep fat frying, bring to temperature on the 'right' side. Introduce cold food and then return to temperature on the 'hotter' left side.

Cooking directly on the hotplate is another facility - griddle scones, burgers, sausages, steaks, and even Welsh Rarebit can be cooked directly on the surface. Meringues can be dried on a baking tray sitting on the hob overnight.

Additionally, by using a barbecue griller you can produce your own toasted sandwiches on the oven top.

The hotplate can be rubbed down with a proprietary cleaning pad if necessary, but normally should need no attention unless spillage is allowed to harden on its surface.

Always keep hotplate covers down except when using the hotplate.

IMPORTANT

The hotplate must not be removed from the cooker, unless the controls are at **OFF** and the cooker isolated from the mains electricity supply.

THE OVENS

NOTE

Do not allow the cooker burner to run for prolonged periods with the top oven door open.

The ovens are fitted with anti-pull out stops to prevent shelves from being pulled out accidentally. To insert the shelf locate the open end of the shelf on the runners, lift up slightly at the front and push to the rear to pass the stops, then fully back into the oven. To remove a shelf, pull forward until it stops, lift front end, pull forward to clear stop, lower shelf and pull out of the oven.

The top oven has four runner positions for the shelves. The wire shelf is used when cooking two trays of food at one time. Certain cooking

operations can be carried out by placing dishes directly on the oven bottom. The oven temperature is controlled thermostatically (if fitted) in accordance with the setting selected on the cooker control knob. A thermometer in the door gives an indication of the oven temperature, but since it is in the door itself, the thermometer will react if the door is opened and the thermometer reading may fall considerably. When the door is closed, the thermometer will recover slowly to indicate the oven temperature. A rapid fall in thermometer reading therefore does not indicate that the oven temperature has also done so. The bottom oven takes its heat from the underside of the top oven, and is approximately $\frac{3}{5}$ of the top oven temperature.

TEMPERATURE SETTINGS

The equivalent gas cooker 'Marks' often quoted in cooking instructions are shown below.

	°F	°C	G.M.
Very Cool	225	110	1/4
	250	130	1/2
Cool	275	140	1
	300	150	2
Moderate	325	170	3
	350	180	4
Moderately Hot	375	190	5
	400	200	6
Hot	425	220	7
	450	230	8
Very Hot	475	240	9

Water Heating (OD MODEL ONLY)

Hot water is produced whenever the burner is alight. For maximum output, turn the control setting to the highest setting and open the direct damper unless high oven temperatures are required.

Servicing

It is essential that the cooker is regularly serviced on an annual basis as described in the Installation and Servicing Instructions. This should be carried out by a qualified person.

NOTE

On completion of the service, the engineer should fill in the Service Record section of the Installation Instructions.

Replacement Parts

When ordering replacement parts, always quote the **Model, Serial No. & Colour** if enamelled parts are required. The serial number data plate is attached to the inside of the accessory box (Fig. 2).

CLEANING AND MAINTENANCE

Cleaning Your Cooker

Wiping the top (and front if necessary) of your cooker clean with a damp cloth during and after use is the easiest way to keep it gleaming.

Spills left to harden will be more difficult to remove. The cooker should be turned down to minimum and the lids left open for a time in order to allow the cooker to cool. Clean with a cloth and washing up liquid, or use the special enamel cleaner available from ESSE. Do not use pan scrubbers on the enamel, as these will leave scratches in the surface. You may use nylon 'abrasive' pads on the inside of the lids with either soapy water or stainless steel cleaner. The outside of the lids should be wiped clean with a damp cloth, then polished with a dry cloth to restore to shine.

Fruit juices and other acidic products may damage the gloss surface of the enamel if not removed quickly.

Always take care not to directly touch a hot surface when cleaning as there is a risk of burning.

The oven will carbonise any splashes when run at maximum temperature. Periodically brush out the bottom of the oven after first turning the cooker to a low temperature and leaving the oven doors open for sufficient time for it to cool so that you are not burnt.

Owner Maintenance

Almost no maintenance ought to be necessary outside the annual service by an experienced engineer.

However the following may prove of use at some point:-

Hotplate rope:- 10mm ceramic rope; this is reattached with either high temperature silicon or a proprietary rope heat bond of the type used on woodburning stoves (also available from ESSE)

Door rope:- Firedoor= 15mm (as above)

Oven doors= 18mm (as above)

Adjusting/tightening the stainless steel lids:- These are affixed by two grub screws, located underneath the rope at approximately 5 o'clock and 7 o'clock. A 4mm Allen key is required.

Decarbonising rod:- This procedure should be carried out every few weeks. Remove the nut covering the decarbonising point (fig. 2). Fully insert the decarbonising rod in and out two or three times to keep the oil intake clear between services. Replace the decarbonising point nut. Tap the agitation pin on the valve (fig. 4) a few times repeatedly. This will clear any small patches that may have come through the oil line and lodged in the valve.

