

REPLACEMENT PARTS

12/07

When ordering spare parts always quote the Serial N°. of the cooker. (The Serial N°. plate is attached to the inside of the burner chamber door).

ON & OD MODELS	CODE N°.
Rectangular Pot	2023-451
Catalyser	2023-452
Control Valve (3 - 9.5 cc/m, 28 or 35 sec oil) 'ON' Model	2023-100
Control Valve (3.5 - 12cc/m, 28 or 35 sec oil) 'OD' Model	2023-120
* Lighting Plug and Chain	2023-046
Lighting Kindler	2023-073
* Ignitor	2023-269
* Timer	2023-270
* Neon	2023-271
* Transformer	2023-272
* IF FITTED	

OIL FIRED COOKERS

INSTALLATION & COMMISSIONING INSTRUCTIONS

MODELS: ON & OD



THE AUTHENTIC ORIGINAL

Ouzledale Foundry Co. Limited, Long Ing, Barnoldswick, Lancashire BB18 6BN
Tel: 01282 813235 Fax: 01282 816876 Email: enquiries@esse.com Website: <http://www.esse.com>



THIS APPLIANCE MUST BE COMMISSIONED BY A OFTEC REGISTERED ENGINEER
THE WARRANTY CARD MUST BE RETURNED TO ENSURE GUARANTEE VALIDITY

HEALTH & SAFETY AT WORK ACT 1974 (AND AMENDMENTS)



The installer has a responsibility under this Act, to provide for the safety of person(s) carrying out the installation.

Attention is drawn to the following:-

- 1) The appliance is heavy and requires care in handling. Lifting off the pallet and positioning may be carried out using the Lifting Jack* available from ESSE dealers. There may also be sharp edges on certain components.
- 2) Fire cement is caustic and hands must be washed thoroughly after use.

Although this appliance does not contain asbestos products, it is possible that asbestos may be disturbed in existing installations and every precaution must be taken.

*Patent applied for.

CONTENTS

General Information	Page 3	Door Hinge Adjustments	Page 14
Storage Tank Installation	Page 4	Fault Finding Chart	Page 15
Installing the Cooker	Page 6	Commissioning Record	Page 16
Commissioning	Page 7	Service Record	Page 16
Chimneys and Flues	Page 7	Replacement Parts	Page 20
Maintenance and Servicing	Page 12		

GENERAL INFORMATION

The installation of the cooker, the chimney, hearth and walls adjacent to the cooker must conform with local or national regulations currently in force. In the United Kingdom, the appropriate sections of the Building Regulations must be conformed to.

IMPORTANT

For the burner to function correctly, a steady chimney draught of 0.76mm (0.03") w.g. to 1.25mm (0.05") w.g. is required, the draught should be assessed with a reliable manometer (using the flue draught test point behind the flue cleaning door) after running the burner at a high control setting for at least thirty minutes. It is recommended that for maximum burning efficiency a draught stabiliser is supplied as standard with the cooker. This should be fitted to the flue above the cooker, hidden if possible but in an accessible place.

A chimney draught lower than 0.51mm (0.02") will result in incorrect combustion with soot formation. Where the draught exceeds 1.53mm (0.6"), or is fluctuating, an additional stabiliser may need to be fitted.

Downdraught cannot be tolerated and arrangements must be made to overcome this condition where it occurs.

Ventilation

A supply of air is necessary for correct combustion and ventilation arrangements should be sufficient

to supply this air. If the construction of the room is such that adventitious air is not available, then ventilation bricks, grids, etc., should be provided in accordance with the the relevant Building Regulations.

An extract fan is not recommended, but where an extract fan is provided to vent the room of cooking smells, steam, etc., arrangements must be made to avoid any possibility of reversing the flow in the chimney. Arrangements for ventilation must always comply with any local by-laws or Code of Practice relevant to the installation.

(Chimney and Flues, p7).

Chimney

A conventional chimney should not be less than 150mm (6") internal diameter. A continuous flexible metallic liner, suitable for oil, is recommended to line an existing chimney. A 125mm (5") liner is normally adequate.

A proprietary, prefabricated chimney should conform to BS4543 and the appropriate Building Regulations.

In all cases the chimney should conform to relevant Building Regulations.

The following points should be noted:-

- 1) The fabric of the chimney must be sound and the internal surface smooth and free from obstructions. Any air leaks and bad joints must be rectified.
- 2) The chimney should be capped to prevent ingress of rain.
- 3) The chimney must service the cooker alone and not be shared with any other appliance.
- 4) External flues of asbestos or cast iron pipe must not be used. Excessive exposure will result in heat loss and poor performance.
- 5) Provision should be made for means of sweeping.

STORAGE TANK INSTALLATION

The installation should only be undertaken by an approved oil appliance installer, and conform with modern installation practice. The storage capacity of the tank should be 1136 litres (250 gallons) minimum, but preferably in excess of 2273 litres (500 gallons) to enable deliveries to be taken at preferential rates. The installer or fuel supplier will normally decide the layout of the tank or installation, but the following general information is given for guidance only (Fig. 1).

- 1) The tank should be of an approved type protected on the outside only and fitted with the following:
 - a) Fill pipe of 50mm (2") nominal bore terminating in a 50mm (2") BSP thread hose coupling connection, complete with non-ferrous screw on cap and keep chain.
 - b) Vent pipe of at least equal diameter to the fill pipe and terminating in a return bend and open mesh balloon.
 - c) Isolating valve on the tank outlet sited slightly above the bottom of the tank to prevent drawing of sediment or water.

Flue

The flue outlet is set for top connection and is suitable for a 125mm (5") flue pipe. We recommend a vertical rise of at least 600mm before any bend. (Chimney and Flues, p8).

Floor

The cooker weighs 320kg (705lbs) approx. The floor must be solid, level and capable of supporting the weight of the cooker.

- d) Drain valve, consisting of a 19mm ($\frac{3}{4}$ ") or 25mm (1") BSP gate valve, plugged to prevent accidental opening, fitted to the baseplate of the tank.
 - e) Contents gauge of a reliable simple type.
- 2) The tank should be installed so that there is 450mm (18") minimum to 3m (10') maximum head of oil above the outlet of the cooker control valve.

The distance from the tank to the cooker will determine the size of oil line but for distances up to 9.15m (30') 10mm o.d. tubing will be sufficient. High loops in which air can accumulate and sharp bends should be avoided.

- 3) The supply line must include a primary filter (120 meshes per linear 25mm (inch) minimum) with a shut-off valve for servicing.
- 4) A fire valve to BS 799 must be incorporated.

Oil Installation - Fig.1

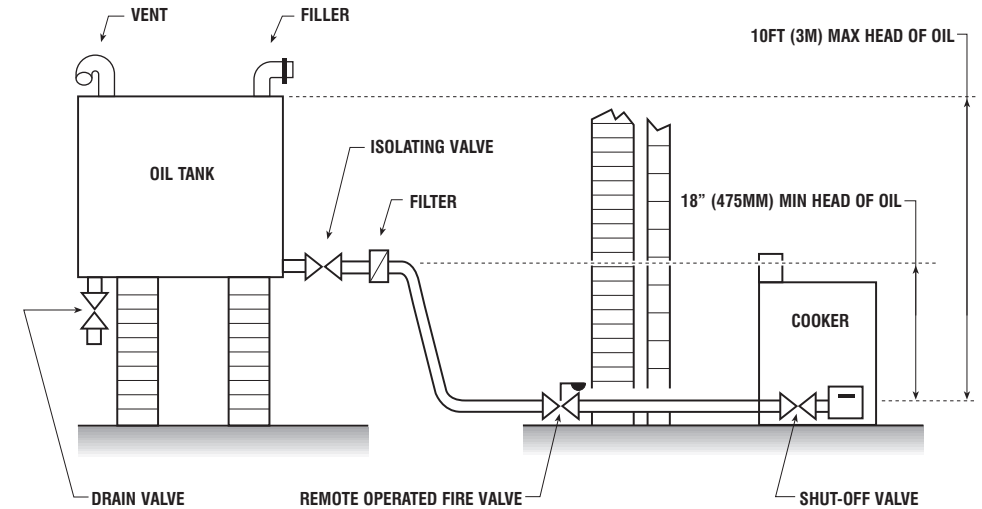

Your Cooker - Fig.2

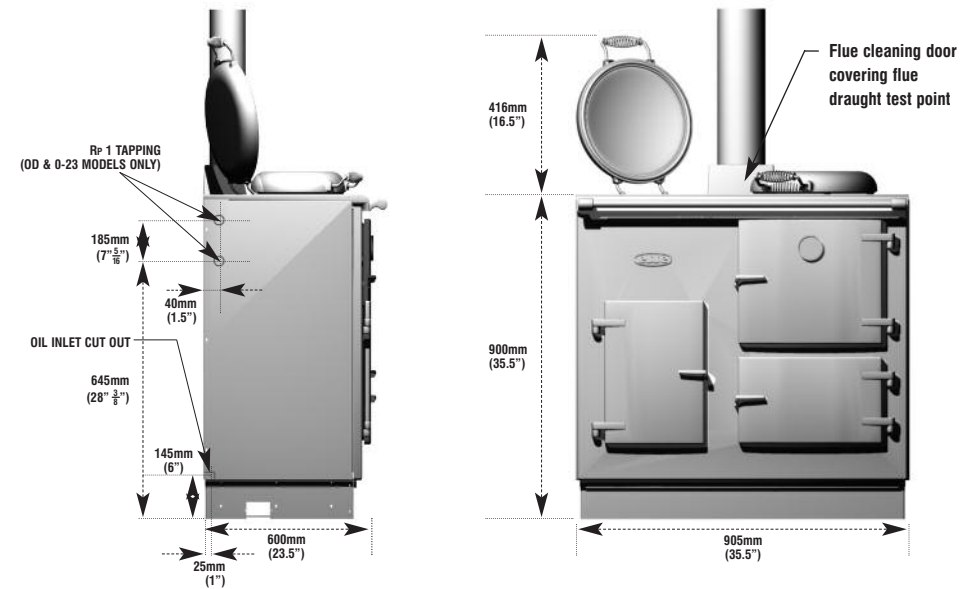

SIZES ARE APPROXIMATE ONLY. VARIATIONS MAY OCCUR IN MANUFACTURE.

INSTALLING THE COOKER

Space Requirements

Refer to Fig. 2

The minimum recommended width of space required to take the cooker is 920mm (36").

Provision is made in the left hand side panel for service connections.

Clearances are not necessary on either side or rear of the cooker for non combustible material. For combustible material, ensure at least 7mm (1/4") gap on either side.

Where the rear wall is of combustible material, current regulations for the installation of heating and cooking appliances must be complied with.

Procedure for Installation

- 1) Unpack the cooker completely and check for any damage.
- 2) Remove the loose components from the ovens.
- 3) Remove the cooker from the pallet and wheel into position using ESSE lifting jacks.
- 4) If the cooker is to be fitted in a narrow space so that the lifting jacks cannot be used, line the cooker up in front of the opening and lower it onto a thin steel plate that extends into the opening. Slide the cooker back on this plate, then lift the cooker at the front and pull out the plate.
- 5) Unpack the flue box cover casting and door. Bed the flue box cover onto a bead of fire cement to make a seal. Fit the white insulation pad to seal and fit the flue box door.

An airtight seal must be made with good quality fire cement between the flue box and flue pipe and flue pipe and flue. In all cases, the important principle that no air must enter the chimney except through the inlets provided on the cooker, must be adhered to.
- 6) Connect to water (if required).

Hot Water System

Model 0D. Maximum hot water output is 2.35kW (8,000Btu/h).

An indirect system is essential for the domestic hot water supply, irrespective of whether the local water is hard or soft.

The boiler will produce hot water when the cooker is in use irrespective of heating demand, and therefore some primary absorption is essential.

This must be gravity operated to allow heat from the boiler to be absorbed at all times. This primary system must be used to provide domestic hot water on an indirect system only.

A 159-181 litre (35-40 gallon) Indirect Cylinder is preferred incorporating a 4000 Btu Heat Leak Radiator (Fig. 3).

The static head must not exceed 18m (60") of water. Under no circumstances should this appliance be fitted to a pressurised system.

Installation as a central heating system alone, i.e. without a domestic supply, is not recommended as the boiler will produce heat when the cooker is in use irrespective of central heating demand, and some primary absorption must be provided.

Whichever system is chosen the layout must follow established heating engineering practise. To avoid trapping air in the boiler a 28mm (1") BSP connection must be used on the primary flow tapping, and any reduction in pipe size thereafter being made on a vertical rising pipe. The cooker must be level when fitted and the flow pipe(s) must rise from the boiler. A drain cock must be fitted on the lowest point of the return pipe and a vent to atmosphere at the highest point of each circuit.

The static head must not exceed 2 bar.

The cylinder being as near the cooker as is possible to avoid long runs of flow and return pipes.

Connect oil and electric supply if required.

Electrical Supply - fig.2a

Models fitted with electrical ignition only

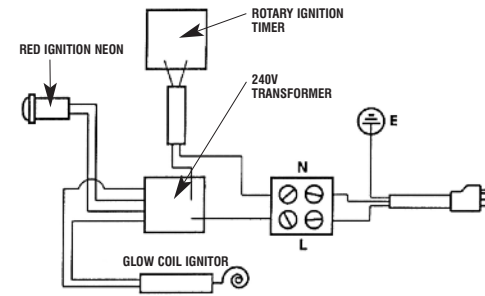

Oil Supply

The cooker is supplied for use on Commercial Kerosene, 28 sec to BS 2869: 1983 Class C2 or 35 sec Heating Oil (Diesel). See data plate. Connection for 1/4" NPT is at the left hand end of the oil valve (Fig. 8). Incoming oil supply should not be less than 8mm (5/16") copper. Access either by removing the left side panel or by removing the accessory box (see Fig. 8).

Remove the plastic covering from the hotplate covers and the inside of the oven doors. Replace the shelves and roasting tin.

Commissioning

- 1) Read the Operating Instructions.
- 2) Remove the 2 hotplate securing screws and remove hotplate. Two screwed lifting handles are provided. Screw into the tapped hole in the hotplate and lift up two or three inches so that the hotplate can be lifted out. CAUTION – The hotplate is heavy and, if dropped on the hob, will cause damage to the enamel.

CHIMNEYS AND FLUES

Function

The function of a chimney and flue pipe is two-fold:

- a) To carry away the products of combustion.
- b) To assist in the supply of combustion air to the burner.

Remove the catalyser (fig. 7), check burner chamber and burner for any extraneous material and wipe away any signs of dampness.

- 3) Open all valves on the oil line from the storage tank, turn oil control valve to highest setting, lift and release the arming lever down and wait for fuel to arrive in the burner. This may take some time as the oil control etc., must first fill with oil.
- 4) When oil arrives, turn the control knob to OFF and check supply lines for any leakage.
- 5) Replace the catalyser components (Fig 7), ensuring it is properly sat down in the pot and replace the hotplate.
- 6) Light the cooker as described in the Operating Instructions and check that the draught requirements are met and that all products of combustion are discharged at the chimney terminal to atmosphere.

Ensure that the burner is operating with a blue flame when the cooker is hot. Check the flue draught stabiliser is operational. This should be located above the cooker. Set the stabiliser to ensure the draught remains between 0.03" w.g. on low setting and 0.04" w.g. on maximum setting. Determine that the smoke number does not exceed 2 by checking with a TRUESPOT or similar device.

Toby valve - the high and low oil flow rates are factory set and should not need adjustment.

Definitions

Chimney: Includes any part of the structure of a building forming any part of a flue, other than a flue pipe.

Flue Pipe: A pipe forming a flue, does not include a pipe built as a lining into a chimney.

Draught

Draught is necessary for both these functions. The hot combustion gases in the chimney are less dense and lighter than the colder air outside and draught is created by this colder air pushing the lighter flue gases upwards.

Typical DHW Gravity System - Fig.3

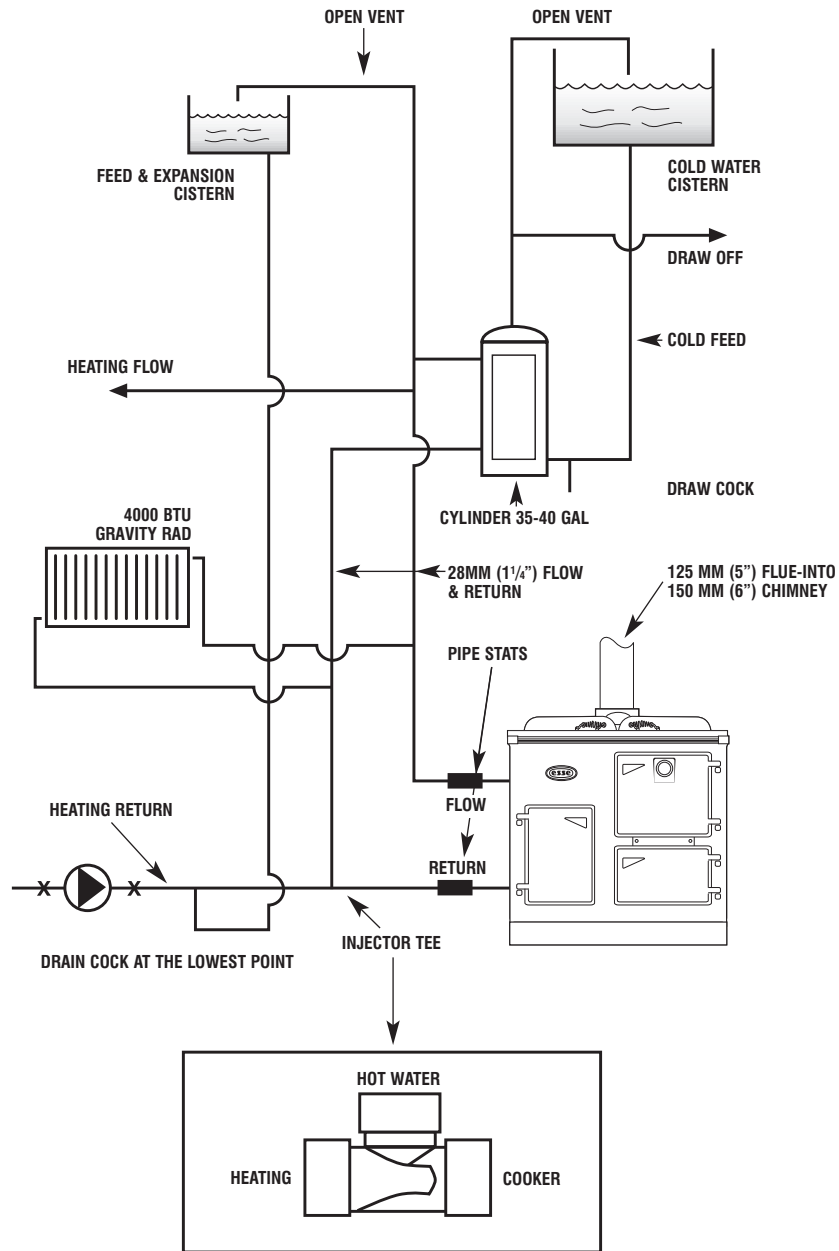

Draught is expressed as a difference in the pressure of the hot flue gases and that of the colder surrounding air. The difference is very small and is measured for practical purposes, as fractions of an inch or mm water gauge. It is recommended that for maximum burning efficiency a 125mm (5") flue draught stabiliser is supplied with the appliance and should be fitted to the flue above the cooker, hidden if possible, but in an accessible place.

Ventilation

Providing adequate air for combustion and ventilation of the appliance is very important for safe and efficient operation. If the flow of air for combustion is inadequate then the flue system will fail and hazardous conditions may arise.

When replacement windows and doors have been installed as refurbishment work in a building, ventilation to a room is very much reduced. It is therefore essential to provide the correct amount of free air to appliances.

Other points worth noting are that it is not permitted to fit 'Fly Screens' over vents or airbricks due to the possibility of the screen clogging up and reducing the air flow, nor is it permissible to use a 'Hit and Miss' vent that can be closed down stopping free air supply. Where an extract fan is provided to vent the room of cooking smells, steam, etc, arrangements must be made to avoid any possibility of reversing the flow in the chimney. Arrangements for ventilation must always comply with any local by-laws or Code of Practice relevant to the installation.

Factors Affecting Chimney and Flue Performance

Several factors contribute towards the satisfactory, or unsatisfactory performance of a chimney and flue. Although these are discussed individually here they should in practice, be regarded as interrelated and interacting.

1) Temperature Differential

The hotter the flue gases in the chimney the greater the pressure differential and therefore

the greater the draught.

2) Height

The height of the chimney has an influence on draught; the higher the chimney the greater the pressure differential and the greater the potential draught. Any interference with the free exit of the flue gases at the chimney top will affect the draught available to the burner. If the chimney is terminated at eaves level or less than three feet above a roof surface, it is probable that the exit of flue gases will encounter opposition from the effects of wind (Fig. 4). This is most likely to occur with pitched roof construction, although turbulence may also be troublesome with flat roofs. Houses may be built in positions where external wind effects can produce excessive draught and cause the burner to operate incorrectly. A serious pressure difference between windward and leeward sides of an exposed house can increase, or even reverse, the gas flow in the chimney. The outlet of any flue in a chimney or flue pipe should always be situated so that the top of the chimney or flue pipe is not less than 1m (3') above the highest point of contact between the chimney or flue pipe and the roof, except where the roof has a pitch on both sides of the ridge of not less than 10 degrees with the horizontal and the chimney or flue pipe passes through the roof at the ridge or within 600mm (2') of it, the top of the chimney or flue pipe may be less than 1m (3'), but not less than 600mm (2') above the ridge. The top of the chimney or flue pipe should not be less than 1m (3') above the top of an openable window or skylight in the roof or external wall and which is not more than 2.3m (7' 6"), measure horizontally, from the top of the chimney or flue pipe. The drawings in Fig. 5 illustrate these points which are in accordance with the Building Regulations. Adjacent buildings or trees higher than the chimney can deflect wind currents and create pressure zones that have an adverse effect on the exit of flue gases (Fig. 6). In bad cases this is almost impossible to correct and, although a cowl may be successful in countering downdraught, fumes may still be carried

down to ground level.

To provide an acceptable draught value for a natural draught burner, for example, it is necessary for the chimney to have a minimum height of 4.8m (16'). Excessive draught conditions can be controlled by the draught stabiliser fitted to the cooker. The draught stabiliser consists of a hinged and weighted flap covering an opening in the flue, the weight can be adjusted so that the effect of the stabiliser will suit individual burner operating conditions, and the flap will thereafter function automatically, swinging open when the draught exceeds requirements and allowing air to by-pass the burner and be drawn directly into the flue.

IMPORTANT

The information given in the section 'General Notes on Chimneys and Flues' is for general information only. Details shown in the main text are definitive and override any conflicting information in this section.

3) Construction

A chimney or flue enclosed within the structure of a building, or having only one or two walls exposed, usually has tolerable heat losses and to some extent these help to warm the building.

Heat can be lost by conduction if the chimney or flue pipe material possess low insulated properties, and an unlined brick chimney with three or four external walls will lose heat rapidly, and thus reduce the draught potential of the chimney. Where the use of an external chimney or flue pipe is unavoidable, it will be necessary to install a lining to conserve the heat in the flue gases.

Heat can also be lost by convection in an existing flue where the cross-sectional area is too large for the requirements of the appliance. In consequence, the flue gases will be exposed to excessive cooling on contact with the flue surfaces. This can introduce re-circulation of the flue gases within the flue to detriment of draught. Considerable reductions in convection and conduction heat

losses can be obtained by reducing the flue to the minimum acceptable diameter.

The combined heat losses by conduction and convection can be sufficient in most cases to chill the flue gases to the point at which condensation can occur in internal flue surfaces. This condition will affect chimney performance and accelerate the break-down of pargeting and mortar and in such cases the chimney should be lined.

The cure for condensation is the installation of a suitable lining to conserve heat, whilst at the same time improving the draught available.

The fabric of the chimney should be sound and internal surface of both flues and chimneys should be smooth and free from obstructions. The internal condition of the flue, such as rough surfaces, broken brickwork and pargeting, as well as dislodged materials and soot falls, can cause abnormal resistance to the flow of the flue gases. Abrupt changes in shape or cross sectional area or too small a cross sectional area or a large number of bends can also offer high resistance to gas flow.

Pointing and pargeting should be made good with cement mortar. In bad cases, where access is difficult, the fitting of a suitable liner is recommended. Where there is evidence of bird nesting the obstruction should be removed and a bird proof terminal fitted.

All abrupt changes in section should be bridged with suitable flue pipe of off-take diameter which conforms to the general size of the flueway. Where a void exists above a register plate the flue pipe (off-take diameter) should be continued up and sealed at the gathering. Where a 229mm (9") square flue opens out into one of larger diameter the flue should be continued by inserting a lining. Where there are bends and horizontal runs, the flue structure should be examined for the possibility of re-routing the flue in new brickwork or, preferably prefabricated chimney material.

Air can enter through badly fitting soot doors and

flue pipe connections, porous brickwork and damaged pointing. All accessible air leaks in brickwork, pointing and pargeting should therefore be sealed with cement mortar, flue pipe joints should be carefully re-made, using suitable jointing material. In old structures, where linings and brickwork are generally leaky, but mechanically sound, air entry may be prevented by installing a suitable lining.

Prefabricated Chimneys

There are many proprietary, prefabricated chimneys available as a substitute for a conventional chimney, but it is necessary to ensure

that both the design and the materials conform to the appropriate Building Regulations.

Chimney Linings

Material to be used for lining chimneys should possess slow permeability to combustion gases to condensate and they must be chemically inert to acids. Suitable forms of clayware and stainless steel flexible material may be used.

Chimney and Flue Performance - Fig.4 (Pressure & suction zones created by wind flow)

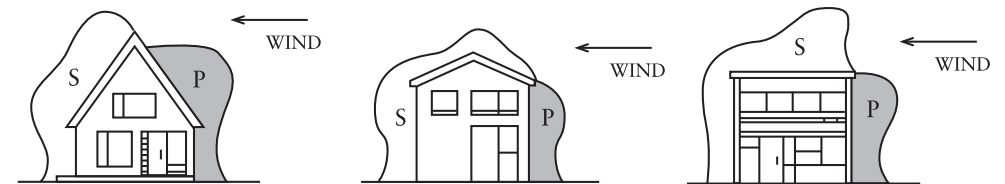

Chimney and Flue Performance - Fig.5 (The position of chimney outlets)

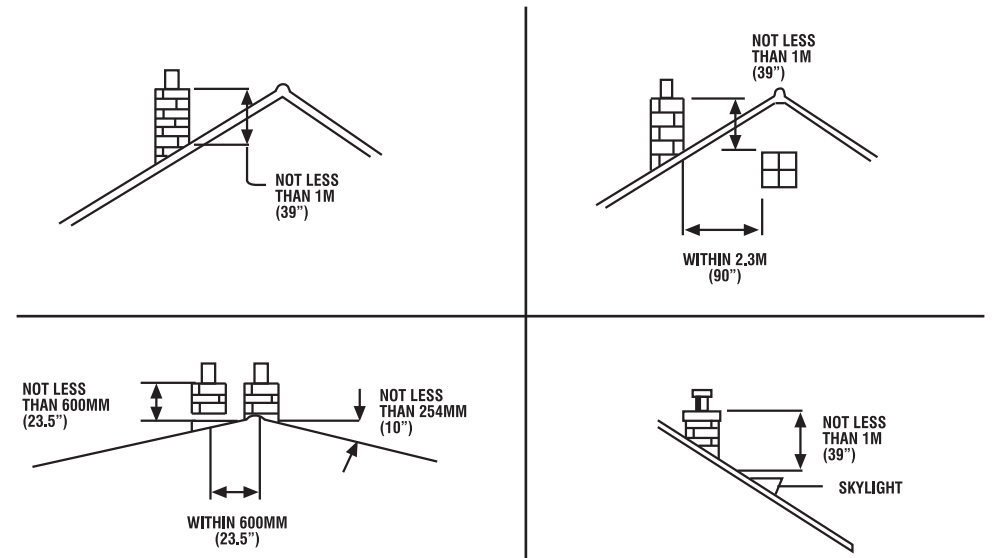

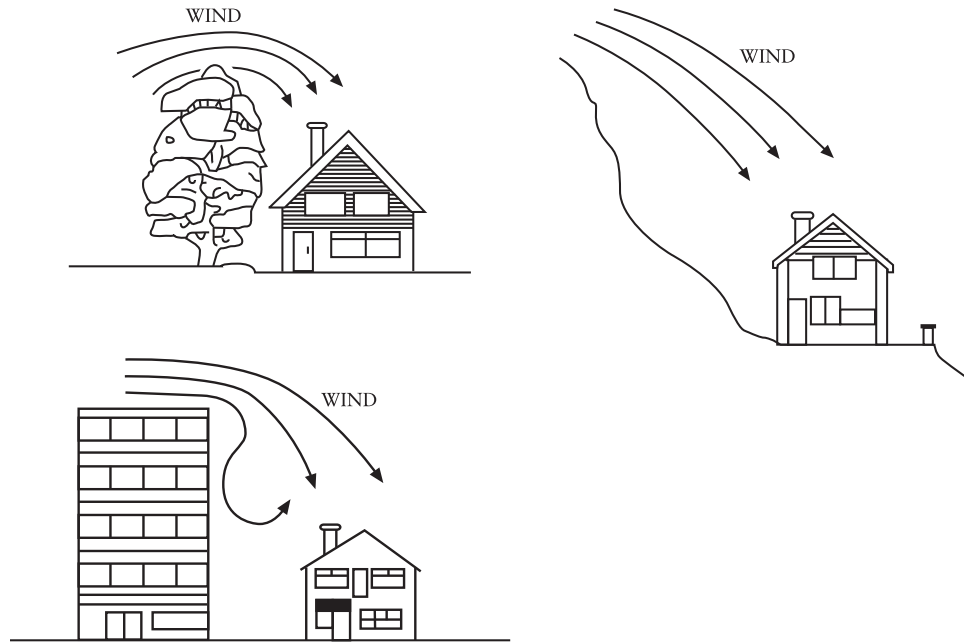

MAINTENANCE AND SERVICING

The cooker should be regularly serviced on an annual basis as described below. This should be carried out by a qualified person and the Service Record completed (p17).

Note: Suitable protection for skin, eyes etc., should be used.

Burner Cleaning

Remove the two hotplate securing screws and remove the hotplate. Two screwed lifting handles are provided, screw them into the hotplate and lift up two or three inches so that the hotplate can be lifted out. **Caution** - the hotplate is heavy and if dropped on the hob will cause damage to the enamel.

Remove the catalyser (fig. 7).

Clean the burner pot using a suitable scraper,

finally brushing down with the wire brush. Remove all deposits from the bottom of the pot by wiping out with a rag.

Replace the catalyser (fig. 7) ensuring it is properly sat down in the pot and then replace the hotplate.

Burner Oil Entry

Where the oil enters the burner, just under the lighting port, carbon may form as a deposit at the inner end, partially blocking the flow of oil. This deposit should be cleared away periodically, preferably whilst cleaning the burner, the method of doing this is as follows:-

Using a suitable spanner slacken the cap on the brass inlet tee. Unscrew the cap and remove, taking care not to lose the sealing washer.

Fully insert the decarbonising rod in and out 2 or 3 times. Replace the cap and washer after cleaning, then tighten up the cap.

Flueways

Access to the cooker flueways is provided at two points - a lift door on the flue box above the hob and a lift-off door below the roasting oven door. Cleaning will be required at intervals, but this will depend on usage and type of fuel.

The combustion products, when the direct damper is closed, pass over the top of the oven, down the right hand side, under the main oven and thence to the chimney by a vertical rear channel. To clean all flueways:-

Remove the hotplate securing screws and lift off the hotplate, burner baffle and vapourising rings. Remove any soot from the boiler faces, burner and oven top. Lift off the flue box cleaning door, insert a flexible flue brush through the mouth of the oven flue uptake and move the brush up and down to dislodge any soot, clean the oven side flue in a similar manner.

Withdraw any soot from the base of the oven through the oven flue cleaning door opening using a raker. Check that all soot has been removed by using an inspection lamp or torch.

On completion replace both cleaning doors, burner components and the hotplate.

Oil Control Valve Filter

The supply lines on the storage tank will contain a filter to collect most of the impurities; this filter should be removed regularly and washed with fuel.

Rectangular Oil Burner Pot - See Fig.7

The oil control contains a filter that acts as a final barrier to any solid impurities and normally will require cleaning no more than once a year. To remove this filter, turn off the oil supply on the oil valve and place a small drain pan under the oil control. The filter is located at the side of the valve behind a pressed steel closure cap. Remove the two screws and withdraw the filter. Wash the filter with clean fuel then replace, taking care that the sealing gasket is in place on the end cap (Fig. 8).

Rectangular Oil Burner Pot - Fig.7

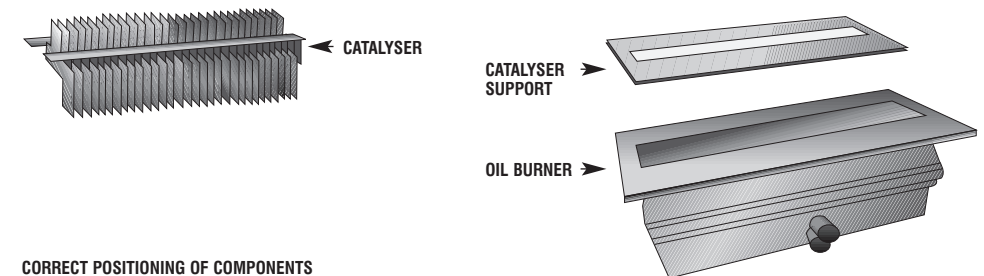

CORRECT POSITIONING OF COMPONENTS

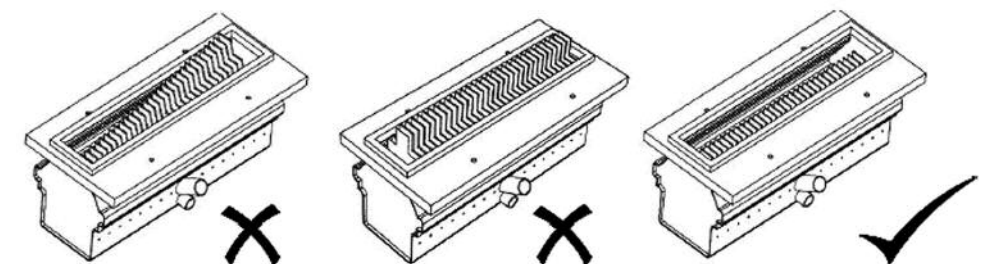

Burner Pot Replacement

The burner pot can be changed without disturbing the cooker top or boiler (if fitted). To do this:-

Undo the oil supply union on the boiler inlet tee. Remove the lighting plug and then the inlet tee assembly.

Remove the hotplate securing screws and lift out the hotplate and the burner catalyser. If fitted, remove the ignitor. To do this, slacken the ignitor security grub screw (this is only accessible from inside the burner pot after removing the burner components). Remove the 4 hex-headed screws securing the burner. Ease the burner downwards to break the cement seal. Remove the burner through the firedoor.

Replace in reverse order, ensuring an airtight seal between the pot and the chamber baseplate.

Oil Control Valve and Accessory Box Removal - Fig.8

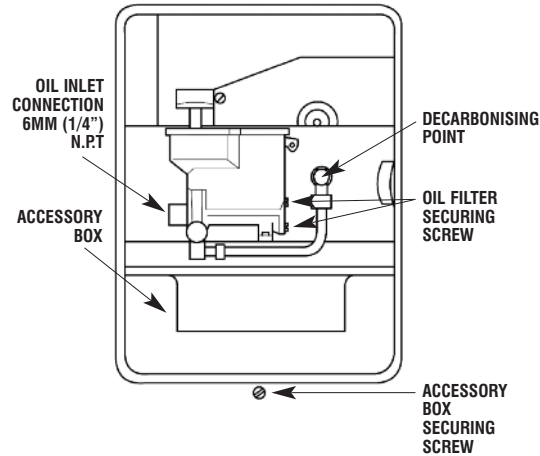

DOOR HINGE ADJUSTMENTS

- 1) Remove upper & lower locking grub screws from hinges using the 3/16" allen key provided.
- 2) Using the same allen key, adjust either or both eccentric pins in each door hinge to level the door.

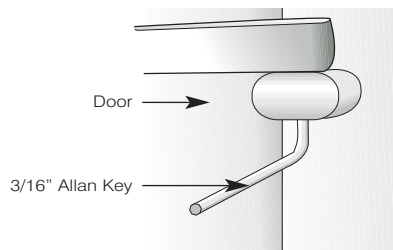

- 3) Once the door is level, lock the eccentric pins in place using the locking grub screws.

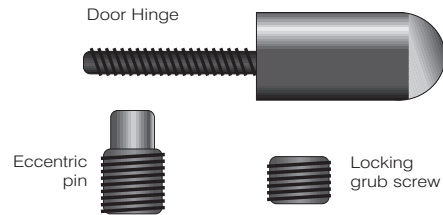

COOKER FAULT FINDING CHART

SITUATION	POSSIBLE CAUSES	REMEDIES
No oil flows to the burner pot or oil control	Oil tank empty	Fill up with correct oil
	Lock out valve closed	Open lock out valve
	Oil control switched to safety position	Lift and release arming lever
Too little oil flows to the burner pot	Burner feed coked	Remove coke
	Valve not level	Level valve
	Oil control is dirty	Clean oil control
Too much oil flows to the burner pot	Oil flow set too low	Calibrate oil control
	Oil flow set too high	Calibrate oil control
Oil flow to burner pot fluctuates	Dirty metering stem slit	Tap the actuating pin Clean the oil control
Safety device is constantly tripped	Oil control very dirty	Clean the oil control
Oil control is turned off and oil still flows to the burner pot	Washer of the metering stem is defective	Renew metering stem washer
	Dirty oil control	Clean the oil control
Poor flue draught	Obstruction	Clear and clean
	Chimney too low	Raise height above ridge, fit flue liner
	Chimney too wide	Fit flue liner
	No flue liner	Fit flue liner
	Flue draught stabiliser incorrectly set	Re-set flue draught stabiliser
Excessive flue draught	Flue draught stabiliser incorrectly set	Re-set flue draught stabiliser
Down draught	High Trees	Raise chimney height
	High buildings	Raise chimney height
	Low chimney	Raise chimney height
	Negative pressure zone	Fit anti-down draught cowl
Cooker smoking	Insufficient air	Provide additional room air
	Chimney choked	Clean chimney
	Down draught	Raise chimney height or fit anti-down draught cowl
Hotplate not heating	Poor combustion	Check air supply, calibrate oil control
	Burner cutting down	Increase cooker thermostat setting
	Utensils not flat	Use machine based utensils
Oven not heating	Direct damper open	Close direct damper
	Flueways blocked with soot	Clean out

COMMISSIONING RECORD

Engineers Name	<input type="text"/>	Date	<input type="text"/>
Address	<input type="text"/>		
	<input type="text"/>		
	<input type="text"/>		
Tel No.	<input type="text"/>	Fax No.	<input type="text"/>
OFTEC/Reg No.	<input type="text"/>		

Engineers Name	<input type="text"/>	Date	<input type="text"/>
Address	<input type="text"/>		
	<input type="text"/>		
	<input type="text"/>		
Tel No.	<input type="text"/>	Fax No.	<input type="text"/>
OFTEC/Reg No.	<input type="text"/>		

Engineers Name	<input type="text"/>	Date	<input type="text"/>
Address	<input type="text"/>		
	<input type="text"/>		
	<input type="text"/>		
Tel No.	<input type="text"/>	Fax No.	<input type="text"/>
OFTEC/Reg No.	<input type="text"/>		

Engineers Name	<input type="text"/>	Date	<input type="text"/>
Address	<input type="text"/>		
	<input type="text"/>		
	<input type="text"/>		
Tel No.	<input type="text"/>	Fax No.	<input type="text"/>
OFTEC/Reg No.	<input type="text"/>		

SERVICE RECORD

Engineers Name	<input type="text"/>	Date	<input type="text"/>
Address	<input type="text"/>		
	<input type="text"/>		
	<input type="text"/>		
Tel No.	<input type="text"/>	Fax No.	<input type="text"/>
OFTEC/Reg No.	<input type="text"/>		

Engineers Name	<input type="text"/>	Date	<input type="text"/>
Address	<input type="text"/>		
	<input type="text"/>		
	<input type="text"/>		
Tel No.	<input type="text"/>	Fax No.	<input type="text"/>
OFTEC/Reg No.	<input type="text"/>		

Engineers Name	<input type="text"/>	Date	<input type="text"/>
Address	<input type="text"/>		
	<input type="text"/>		
	<input type="text"/>		
Tel No.	<input type="text"/>	Fax No.	<input type="text"/>
OFTEC/Reg No.	<input type="text"/>		

Engineers Name	<input type="text"/>	Date	<input type="text"/>
Address	<input type="text"/>		
	<input type="text"/>		
	<input type="text"/>		
Tel No.	<input type="text"/>	Fax No.	<input type="text"/>
OFTEC/Reg No.	<input type="text"/>		

Engineers Name	<input type="text"/>	Date	<input type="text"/>
Address	<input type="text"/>		
	<input type="text"/>		
Tel No.	<input type="text"/>	Fax No.	<input type="text"/>
OFTEC/Reg No.	<input type="text"/>		

Engineers Name	<input type="text"/>	Date	<input type="text"/>
Address	<input type="text"/>		
	<input type="text"/>		
Tel No.	<input type="text"/>	Fax No.	<input type="text"/>
OFTEC/Reg No.	<input type="text"/>		

Engineers Name	<input type="text"/>	Date	<input type="text"/>
Address	<input type="text"/>		
	<input type="text"/>		
Tel No.	<input type="text"/>	Fax No.	<input type="text"/>
OFTEC/Reg No.	<input type="text"/>		

Engineers Name	<input type="text"/>	Date	<input type="text"/>
Address	<input type="text"/>		
	<input type="text"/>		
Tel No.	<input type="text"/>	Fax No.	<input type="text"/>
OFTEC/Reg No.	<input type="text"/>		

Engineers Name	<input type="text"/>	Date	<input type="text"/>
Address	<input type="text"/>		
	<input type="text"/>		
Tel No.	<input type="text"/>	Fax No.	<input type="text"/>
OFTEC/Reg No.	<input type="text"/>		

Engineers Name	<input type="text"/>	Date	<input type="text"/>
Address	<input type="text"/>		
	<input type="text"/>		
Tel No.	<input type="text"/>	Fax No.	<input type="text"/>
OFTEC/Reg No.	<input type="text"/>		

Engineers Name	<input type="text"/>	Date	<input type="text"/>
Address	<input type="text"/>		
	<input type="text"/>		
Tel No.	<input type="text"/>	Fax No.	<input type="text"/>
OFTEC/Reg No.	<input type="text"/>		

Engineers Name	<input type="text"/>	Date	<input type="text"/>
Address	<input type="text"/>		
	<input type="text"/>		
Tel No.	<input type="text"/>	Fax No.	<input type="text"/>
OFTEC/Reg No.	<input type="text"/>		