

## REPLACEMENT PARTS

12/07

UNIVERSAL	PART No.
Burner	2023-253
Piezo Ignitor	2023-099
Piezo H.T. Lead	2023-146
Solenoid	2023-260
PROPANE ONLY	
Eurosit Control	2023-093P
Oxy Pilot Assembly	2023-259
NATURAL GAS ONLY	
Eurosit Control	2023-093N
Oxy Pilot Assembly	2023-258

When ordering replacement parts, quote the cooker serial number and Gas type.

# GAS FIRED COOKERS

## INSTALLATION & COMMISSIONING INSTRUCTIONS

MODELS: GN & GD



Ouzledale Foundry Co. Limited, Long Ing, Barnoldswick, Lancashire BB18 6BN  
Tel: 01282 813235 Fax: 01282 816876 Email: [enquiries@esse.com](mailto:enquiries@esse.com) Website: <http://www.esse.com>

THE AUTHENTIC ORIGINAL

## HEALTH & SAFETY AT WORK ACT 1974 (AND AMENDMENTS)



The installer has a responsibility under this Act, to provide for the safety of person(s) carrying out the installation.

Attention is drawn to the following:-

- 1) The appliance is heavy and requires care in handling. Lifting off the pallet and positioning may be carried out using the Lifting Jack\* available from ESSE dealers. There may also be sharp edges on certain components.
- 2) Fire cement is caustic and hands must be washed thoroughly after use.

Although this appliance does not contain asbestos products, it is possible that asbestos may be disturbed in existing installations and every precaution must be taken.

\*Patent applied for.

### IMPORTANT:

This cooker must be installed in accordance with regulations in force and only used in a well ventilated space. Read these instructions before installing or using.

### GAS CATEGORIES:

Natural Gas Models - 2nd Family --- 1 2H  
Propane Gas Models - 3rd Family --- 1 3P

### COUNTRY OF DESTINATION:

GB AND IE

## CONTENTS

General Information	Page 3	Oven Control	Page 7
Flue System	Page 4	Commissioning	Page 8
Building in the Cooker	Page 5	Maintenance and Servicing	Page 9
Door Hinge Adjustments	Page 6	Fault Finding Chart	Page 12
Hot Water System	Page 6	Commissioning Record	Page 13
Gas Control System	Page 6	Service Record	Page 13
		Replacement Parts	Page 16

## GENERAL INFORMATION

The installation of the cooker, the chimney, hearth and walls adjacent to the cooker must be in conformity with local or national regulations currently in force. In the United Kingdom, the appropriate sections of the Building Regulations must be conformed to.

The cooker weighs 300kg (662lbs) approx. The floor must be solid, level, and constructed in accordance with any Building Regulations which apply to the particular site.

The cooker is supplied fitted for either Natural or L.P. Gas, and the fuel type is marked on a data badge fixed to the inside of the burner chamber door.

Check the data plate specification corresponds to the available gas supply before starting installation.

### Ventilation

The cooker requires the room or internal space containing it, to have an air vent of minimum effective area of 9cm<sup>2</sup> (3<sup>1</sup>/<sub>2</sub>"<sup>2</sup>). This air vent should be either direct to outside air, or to an adjacent room or internal space that itself has an air vent direct to outside air. (Reference current BS5440 Part 2).

It should be noted that the cooker will generate a certain amount of convected heat and ventilation arrangements should allow for this.

An extractor fan is not recommended, but where an extractor fan is provided to vent the room of cooking smells, steam, etc., arrangements must be made to avoid any possibility of reversing the flow in the chimney. Arrangements for ventilation must always comply with any local by-laws or Code of Practice relevant to the installation.

### Gas Service

Check that the gas meter and service pipe are both of adequate size to meet the requirements of the cooker and any other appliances that may be fitted on the system.

The maximum heat input, based on the gross calorific value of the fuel, is 8.8kW. For propane this converts to 629 gram/hour (1.39lbs/hour).

## FLUE SYSTEM

Refer to Figs. 1 and 2.

An efficient flue system must be provided for the removal of products of combustion and reference should be made to current Codes of Practice (BS5440 Parts 1 and 2).

Use 500mm (20") minimum of vertical flue pipe from the boiler flue socket (Figs. 1 & 2).

Run the flue in the most direct and vertical route practicable. Avoid horizontal or shallow runs but where a horizontal section is necessary, offset this by using twice its length of vertical flue.

To avoid condensation, all flues must be protected against undue cooling. Use internal flues whenever

possible; external flues must be insulated and external brick stack lined.

Where condensation is likely, provide means of draining.

Terminate the flue to avoid draught or wind eddies.

### NOTE

The flue socket on the boiler is designed for 100mm (4") pipe to BS41 and this should not be decreased at any point on the flue run. The advice of a competent installer should be sought in cases of difficulty.

Connection to Brick Chimney - Fig.1

Termination of Flue on Roof - Fig.2

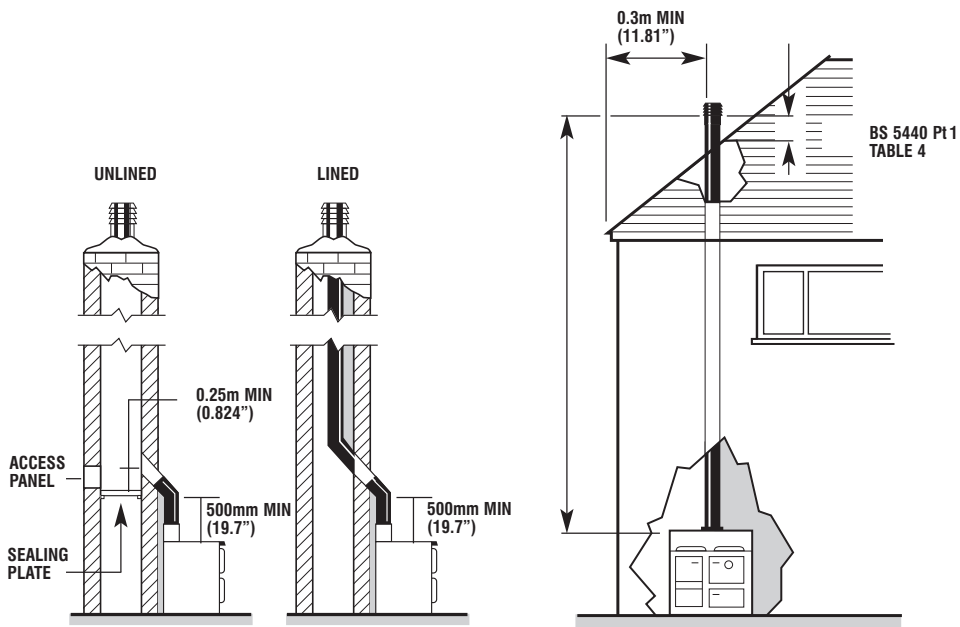

## BUILDING IN THE COOKER

Normal Heat Input - Fig.3

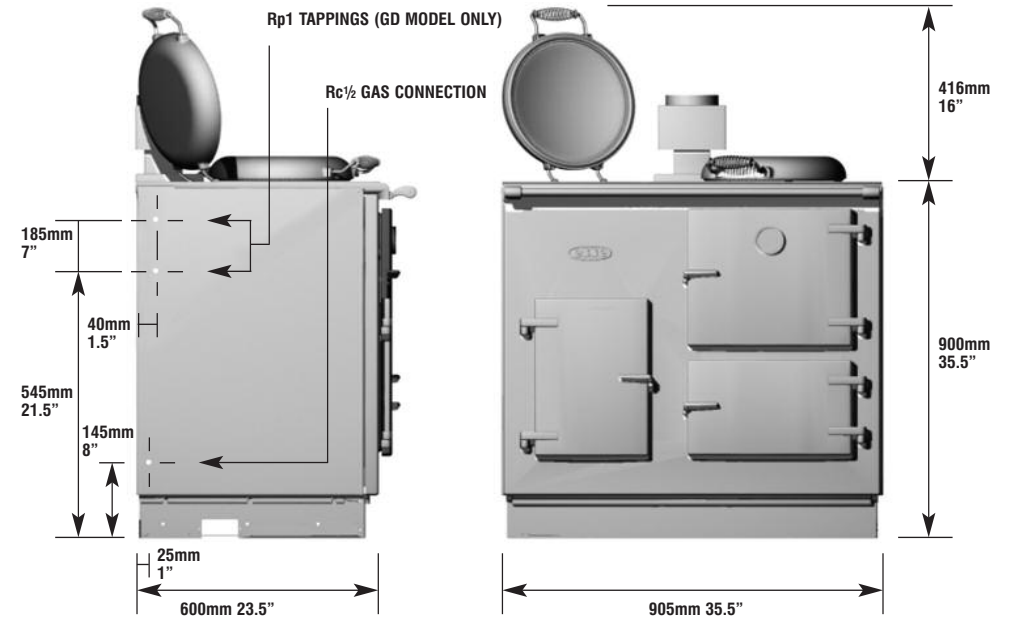

Sizes are approximate only. Variations may occur in manufacture.

### Space Requirements

Refer to Fig. 3

The minimum recommended width of space required to take the cooker is 920mm (36").

Provision is made in the left hand side panel for service connections.

Clearances are not necessary on either side or rear of the cooker for non combustible material. For combustible material, ensure at least a 7mm (1/4") gap on either side.

Where the rear wall is of combustible material, current regulations for the installation of heating and cooking appliances must be complied with. The cooker is supplied assembled and ready for connection to gas and water. The gas connection is RC 1/2 in the union cock at the lower left hand rear.

### Procedure for Assembly

Unpack the cooker completely and check all loose parts against the checklist provided. Inspect for any

transit or other damage. For ease of movement, the three doors can be removed and stored carefully to avoid damage. Move the cooker into its final position and make gas, water and electrical connections as necessary. Place the fluebox loosely on the hob, screw down and make the flue connection.

### IMPORTANT

Flue pipe must rise 500mm (20") vertically before any 90 degree bend is fitted. This can be reduced to 300mm (12") if a more obtuse bend is used.

Fit the towel rail using the towel rail brackets supplied.

Replace the three doors, the shelves and roasting tin. Check the hotplate is level. Check that the hotplate covers lift easily and stay in the upright position when raised.

Remove the plastic protection from the hotplate covers and from the inside of the oven doors.

## DOOR HINGE ADJUSTMENTS

- 1) Remove upper & lower locking grub screws from hinges using the 3/16" allen key provided.
- 2) Using the same allen key, adjust either or both eccentric pins in each door hinge to level the door.
- 3) Once the door is level, lock the eccentric pins in place using the locking grub screws.

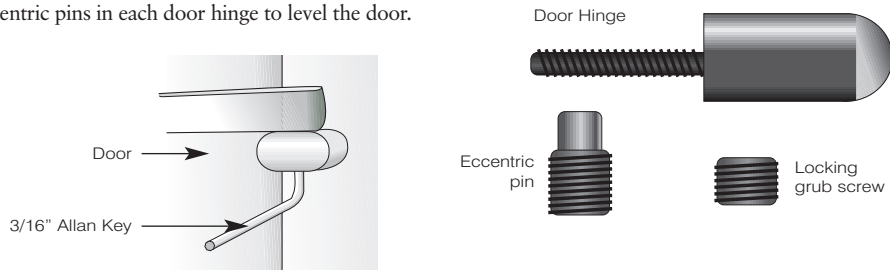

## HOT WATER SYSTEM - GD ONLY

Maximum output at highest oven temperature is 2.5 kW.

- 1) An indirect system is essential for the domestic hot water supply, irrespective of whether the local water is hard or soft.

Cylinder capacity should not be less than 136 litres (30 gallons).

- 2) The boiler tappings are Rp1. Connection may be made through the backplate or through the left hand side panel. The flow tapping must be 28mm (1 1/4") pipe and any reduction made on a rising section of the piping.

- 3) The water circuit must be for gravity flow.
- 4) Water circuit layout must follow established heating practice. The cooker must be level when fitted and the flow pipe must rise from the boiler. A drain cock must be fitted at the lowest point of the circuit and a permanent vent to atmosphere provided at the highest point.
- 5) The cylinder and pipework must be insulated to avoid heat losses.
- 6) The static head must not exceed 2 Bar.
- 7) It must be noted that the boiler will produce hot water whenever the burner is in operation.

## GAS CONTROL SYSTEM

Gas enters at the left hand side of the cooker via a RC 1/2 connection. A square head service cock is provided. It is ON when the inscribed line is in line with gas flow. Appliances are despatched from the

factory with the cock in the ON position and must remain in that position unless it is required to turn it OFF for servicing etc. (Figs. 5, 6, 7 & 8).

## OVEN CONTROL

This is a multi-functional control incorporating a thermo-electric flame failure valve, rotary tap and thermostatic control. The thermostat (100°C - 300°C (212°F - 572°F)) terminates in a phial clamped to the inside of the oven. This control is connected to the oven burner.

A 7-day electronic timer is fitted as standard. A by-pass valve is also fitted for use in event of electrical power not being available.

The burner has a pilot, thermocouple and ignitor.

### IMPORTANT

The cooker is despatched, set up to operate on the gas specified and must be used on the appropriate fuel. Fuel type is marked on the data plate.

### Gas Pressure

No pressure control is provided on the cooker and the supply must be set to give an inlet pressure of:-

Natural Gas - 20mbar  
Propane - 37mbar

An inlet pressure test point and a setting pressure test point are provided on the control valve.

Setting pressure :-  
Natural Gas - 17.0mbar  
Propane - 23.5mbar

Burner Injector

TYPE: BRAY 82

SIZE: 650 Natural Gas G20  
300 Propane G31.

Electricity Supply

The appliance requires a main electrical supply of 230 volts AC 50hz. This supply must be earthed and provided with a 3 amp fuse. One cable is supplied which is live to the electronic timer (Fig 4).

Wiring Instructions for Horstmann Electronic Timer - Fig 4 and The Control Panel - Fig.4a

### NOTE

Terminal 4 is only live when the Horstmann Timer is calling for heat

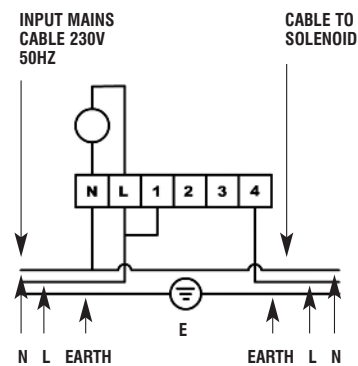
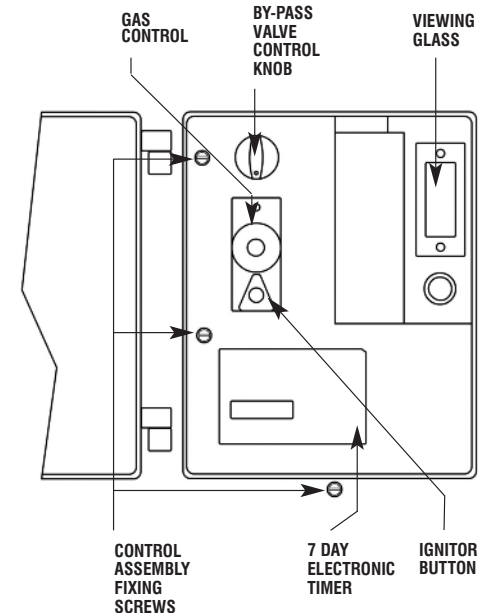

Fig 4



## Commissioning

With the cooker installed and connected to gas, water and electricity proceed as follows:-

- 1) Pull off the by-pass control knob. Remove control panel, using the 3 control assembly fixing screws (Fig. 4a), connect pressure gauge to test point on control inlet (Fig. 6). Check to ensure that appliance is ON.
- 2) Purge the pipework system of air. This can be done via the pressure test point or by holding the gas control lighting button until gas flows from the pilot.
- 3) Light the pilot. Leave main burner OFF. Check the pilot flame length through the inspection glass - flames should be approx. 20mm (4/5") long.
- 4) Refer to the users instructions. Lift the hotplate covers to the upright position and light the burner. Check that the supply pressure is in accordance with that given in the GAS

PRESSURE section (p6). Turn the main burner off, remove the pressure gauge, replace the pressure test screw and test for gas soundness. Replace the controls panel and by-pass control knob. Light the burner. Allow the cooker to heat up for 45 minutes. Because of the initial cold mass of metal, there will be some initial condensation and/or steaming but this should disappear as the cooker heats up. The hotplate covers are raised to prevent initial condensation affecting the soft seal fixative, wait 15 minutes, then turn the oven control knob to its lowest setting and check that the oven burner flame reduces to low rate - a flame length of about 3mm (1/4") over the burner. Turn the burner off, leaving the pilot alight.

The low rate of the burner is approx. 1.2 kW.

Control Assembly - Fig.5

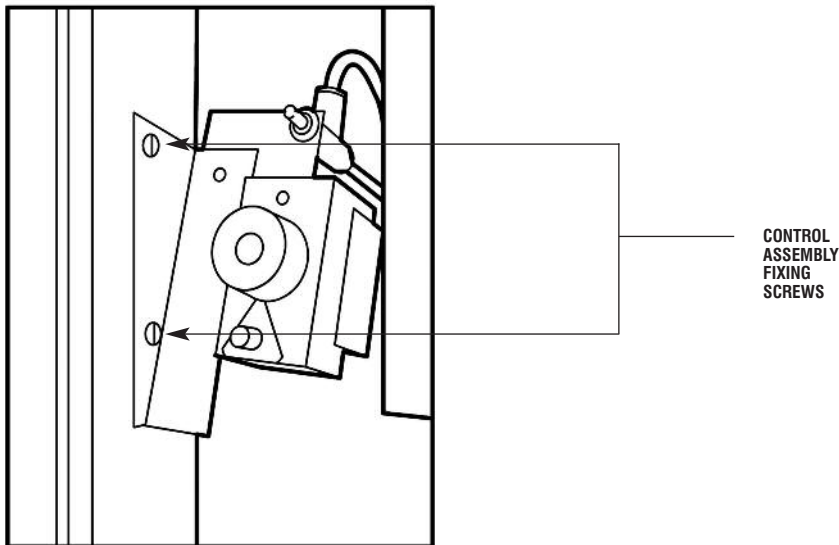

## MAINTENANCE & SERVICING

### Eurosit Control

This is a single knob multifunctional control incorporating thermoelectric flame failure protection together with a thermostatic section using a phial type sensor. The thermostat will modulate the gas rate over its specific range and then down to the snap off position.

The inlet and outlet connections are R3/8 Female. Double inlet and outlet connections are available and the unused connection is plugged off. This must not be disturbed. The unit contains a restart interlock to avoid re-ignition safety i.e. when turned off the control must be allowed to stand in the off position for several minutes before the burner can be relit. The pilot may light but will go out as soon as the knob is released.

The gas rate to the burner is fixed by an adjusting screw in the outlet plug. This plug must not be interfered with since unscrewing will affect the gas input. The screw is sealed with red paint before despatch (Propane) or black paint (Natural Gas).

The minimum rate screw also has an adjusting screw and must not be interfered with. Sealing colours are as for gas rate plug.

A piezo ignitor is included within the cover assembly. This cover is fixed by one screw at the upper front.

### Operation

Refer to Users Instructions - Turn knob to ignition position, press knob fully inwards and light pilot, release knob after 10 seconds, turn to full on position.

### Pilot Rate Adjustment

Pre-set no adjustment required.

### Minimum Rate Adjustment

Pre-set no adjustment required.

### To Remove Parts

- a) Burner Chamber Door - Simply lifts off.
- b) Controls Panel - Remove three screws (Fig 4).
- c) Heatshield - Remove two wing nuts. Lift off heatshield.

### Burner/Controls/Pipework Removal (Figs. 5,8 & 9)

- a) Burner Assembly - Remove parts as described above. Isolate gas supply. Undo union on burner supply at control. Remove two screws fixing burner assembly to combustion chamber. Remove two screws fixing controls assembly (Fig. 5) Remove whole assembly.
- b) Pilot Assembly - Pull off ignitor lead at electrode. Undo union nut on pilot supply at control. Undo union nut on thermocouple. Remove lint arrester. Remove two screws from underside of pilot bracket. Remove whole assembly.
- c) Burner from Assembly - Undo union nut on injector. Remove two nuts from underside of burner.
- d) Injector - Remove burner end plate (two screws). Remove injector locating nut.
- e) Eurosit Control and Solenoid - Undo union nut on each end of the supply from service cock to control. Remove supply pipe. Undo union nut on pilot supply. Undo thermocouple fixing nut. Pull off ignitor lead. Open oven door, remove thermostat phial from its clip on the oven roof. Remove two screws securing Eurosit fixing bracket to the cooker frame. Remove Eurosit and solenoid.

### IMPORTANT

The thermostat phial and capillary pass between cooker front and combustion chamber and can lead to difficulty when replacing. To avoid this, sellotape a length of thin string or wire to the end of the phial before removing it from the oven. Feeding the string through as the capillary is withdrawn. This will provide a guideline when the new control is fitted.

### Servicing

The cooker should be serviced once each year by an authorised person. The following parts should be removed and cleaned as detailed below.

### Hotplate

Care must be taken with the hotplate when removing or replacing as damage can occur to the enamelled surface. Remove the two hotplate securing screws and lift out the hotplate using the two screwed tools supplied to the user. Brush the underside with a wire brush.

### Burner Assembly

Remove burner/controls/pipework as previously described. Check top surface for any dust or debris. Brush down as necessary. On completion, replace all parts.

### Cooker Interior (Burner Chamber)

Sweep out any debris from the burner chamber, use a vacuum cleaner nozzle if necessary. At no time during servicing should the gas rate screw and the low flame screw be disturbed.

Eurosit Control (Side view) - Fig.6

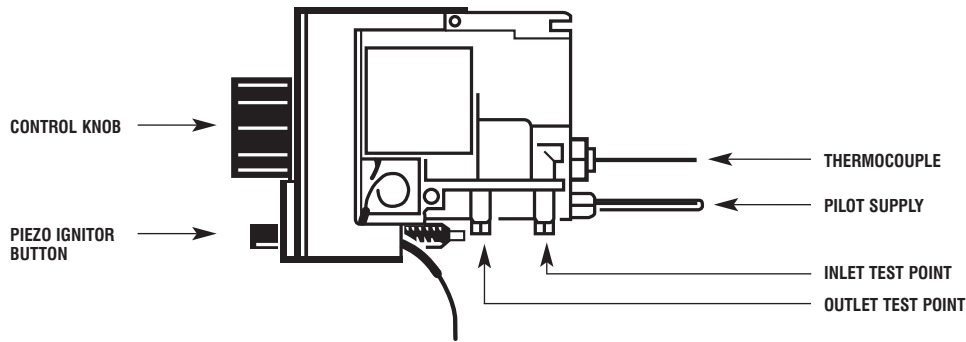

Eurosit Control Connections and Rate Screws - Fig.7

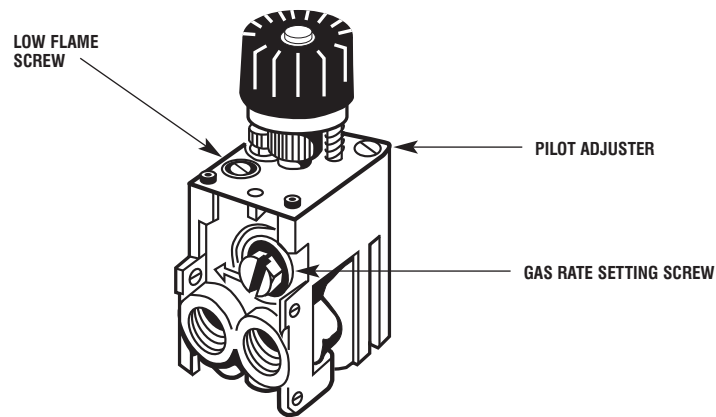

Gas Components - Schematic Arrangement - Fig.8

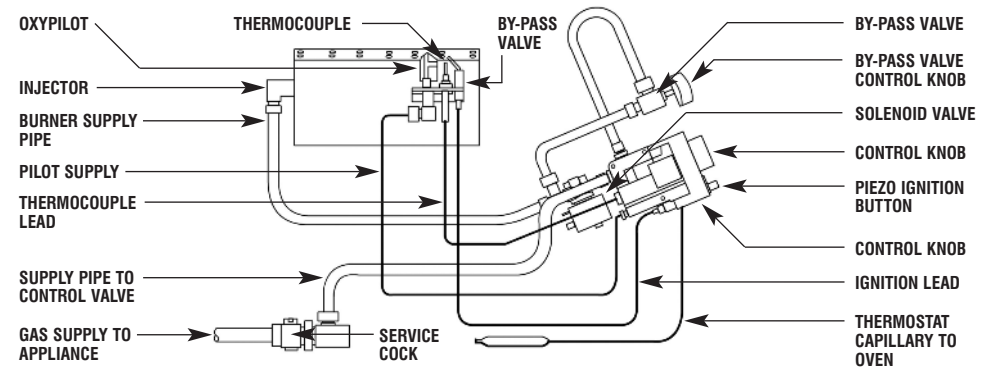

Breakdown of Burner Assembly - Fig.9

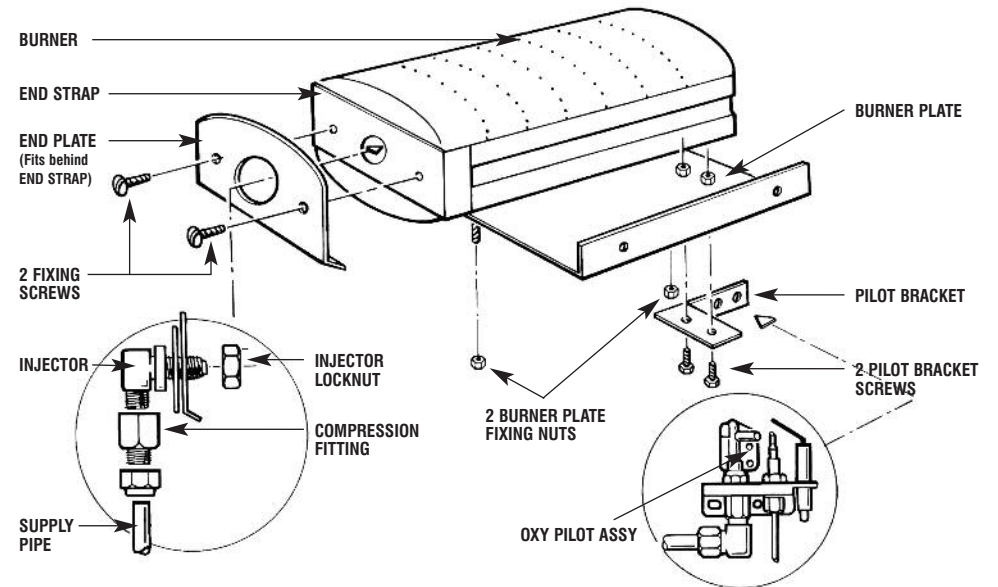

## BOILER/COOKER FAULT FINDING CHART

SITUATION	POSSIBLE CAUSES	REMEDIES
No gas to pilot	Isolation valve closed	Open isolation valve
	Pilot blocked	Remove and clean pilot assembly or replace.
No spark to pilot	Piezo lead detached	Connect piezo lead
	Spark gap incorrect	Adjust spark gap
	Piezo faulty	Replace piezo
	Piezo lead faulty	Replace piezo lead
Pilot light won't stay lit or keeps going out	Dirty/loose thermocouple connection	Tighten/clean thermocouple connection into rear of gas valve
	Faulty thermocouple	Replace pilot assembly
	Pilot flame too short	Remove and clean pilot assembly or replace
	Blocked lint arrestor	Clean lint arrestor
	Fuming out from draught diverter causing oxygen depletion pilot to shut off	Correct poor draught
Oven stays too hot	Minimum rate set too high	Re-set minimum rate
	Thermostat faulty	Change control valve complete with thermostat
Oven stays too cool	Thermostat faulty	Change control valve complete
Poor flue draught	Obstruction	Clear and clean
	Chimney too low	Raise height above ridge
	Chimney too wide	Fit flue liner
	No flue liner	Fit flue liner
Down draught (fuming out from down draught diverter)	High trees	Raise chimney height
	High buildings	Raise chimney height
	Low chimney	Raise chimney height
	Negative pressure zone	Fit anti-down draught cowl
Cooker not heating	Burner cutting down	Increase cooker thermostat setting
	Burner cutting down control valve complete	Faulty thermostat – change
	Utensils not flat	Use machine based utensils

## COMMISSIONING RECORD

Engineers Name	<input type="text"/>	Date	<input type="text"/>
Address	<input type="text"/>		
	<input type="text"/>		
Tel No.	<input type="text"/>	Fax No.	<input type="text"/>
OFTEC/Corgi Reg No.	<input type="text"/>		

## SERVICE RECORD

Engineers Name	<input type="text"/>	Date	<input type="text"/>
Address	<input type="text"/>		
	<input type="text"/>		
Tel No.	<input type="text"/>	Fax No.	<input type="text"/>
OFTEC/Corgi Reg No.	<input type="text"/>		

Engineers Name	<input type="text"/>	Date	<input type="text"/>
Address	<input type="text"/>		
	<input type="text"/>		
Tel No.	<input type="text"/>	Fax No.	<input type="text"/>
OFTEC/Corgi Reg No.	<input type="text"/>		

Engineers Name	<input type="text"/>	Date	<input type="text"/>
Address	<input type="text"/>		
	<input type="text"/>		
Tel No.	<input type="text"/>	Fax No.	<input type="text"/>
OFTEC/Corgi Reg No.	<input type="text"/>		

Engineers Name	<input type="text"/>	Date	<input type="text"/>
Address	<input type="text"/>		
	<input type="text"/>		
Tel No.	<input type="text"/>	Fax No.	<input type="text"/>
OFTEC/Corgi Reg No.	<input type="text"/>		

Engineers Name	<input type="text"/>	Date	<input type="text"/>
Address	<input type="text"/>		
	<input type="text"/>		
Tel No.	<input type="text"/>	Fax No.	<input type="text"/>
OFTEC/Corgi Reg No.	<input type="text"/>		

Engineers Name	<input type="text"/>	Date	<input type="text"/>
Address	<input type="text"/>		
	<input type="text"/>		
Tel No.	<input type="text"/>	Fax No.	<input type="text"/>
OFTEC/Corgi Reg No.	<input type="text"/>		

Engineers Name	<input type="text"/>	Date	<input type="text"/>
Address	<input type="text"/>		
	<input type="text"/>		
Tel No.	<input type="text"/>	Fax No.	<input type="text"/>
OFTEC/Corgi Reg No.	<input type="text"/>		

Engineers Name	<input type="text"/>	Date	<input type="text"/>
Address	<input type="text"/>		
	<input type="text"/>		
Tel No.	<input type="text"/>	Fax No.	<input type="text"/>
OFTEC/Corgi Reg No.	<input type="text"/>		

Engineers Name	<input type="text"/>	Date	<input type="text"/>
Address	<input type="text"/>		
	<input type="text"/>		
Tel No.	<input type="text"/>	Fax No.	<input type="text"/>
OFTEC/Corgi Reg No.	<input type="text"/>		

Engineers Name	<input type="text"/>	Date	<input type="text"/>
Address	<input type="text"/>		
	<input type="text"/>		
Tel No.	<input type="text"/>	Fax No.	<input type="text"/>
OFTEC/Corgi Reg No.	<input type="text"/>		

Engineers Name	<input type="text"/>	Date	<input type="text"/>
Address	<input type="text"/>		
	<input type="text"/>		
Tel No.	<input type="text"/>	Fax No.	<input type="text"/>
OFTEC/Corgi Reg No.	<input type="text"/>		