

Cooker Model:	_____
Serial Number:	_____
Colour:	_____

GAS FIRED COOKERS

OPERATING INSTRUCTIONS

MODEL: CAT - Enabled

GUARANTEE

CONDITIONS OF GUARANTEE

Your **esse** cooker is guaranteed against defects arising from faulty manufacture for three years, subject to the following express conditions:

- This cooker must be commissioned by your esse Dealer (or an authorised CORGI engineer) upon installation. The details must be recorded on the Commissioning card and registered with esse by returning the completed card. The guarantee period commences upon delivery of the cooker (subject to receipt of the correctly completed card).
- The cooker has been used for normal domestic purposes only, and in accordance with the manufacturer's instructions.
- The cooker is serviced annually by the esse Dealer or authorised CORGI engineer, and the Service record completed. The cooker must not be serviced, maintained, repaired, taken apart, or tampered with by any person not authorised by us.
- Any cooker or defective part replaced shall become the Company's property.

EXCLUSIONS

This guarantee does not cover:

- Damage OR calls resulting from transportation, improper use or neglect.
- Parts deemed to be replaceable in the normal usage of the cooker. These parts are listed herewith: oven thermostat, gas valve, piezo ignition lead, pilot assembly, timer/programmer and catalyser assembly.
- Enamel damage; the vitreous coating on your cooker is in effect an extremely thin layer of glass and as such displays all the characteristics of glass. It can easily be damaged by impact, or by spillage of cold liquids onto a hot surface. Such damage cannot be covered under this guarantee. (See also intermittent use of your cooker, below).

This guarantee is personal to the original purchaser and is non-transferable.

INTERMITTANT USE OF YOUR COOKER

In the event of intermittent use and prolonged shutdown, it should be noted that in some circumstances enamel may become displaced due to ingress of damp. Whilst this is rare, it is most likely to occur in situations where the unused cooker remains in an unheated property. There is a layer (known as the groundcoat) between the vitreous enamel surface and the cast iron. Groundcoat is porous and if exposed (e.g. after a chip in the vitreous enamel coat), may allow damp to penetrate behind the vitreous enamel and spread through the groundcoat. Surface oxidation of the cast iron may thereafter occur, causing the vitreous enamel to fall off. Such damage will not be covered by your warranty.

We recommend that a light coating of petroleum jelly be applied to any damaged areas when the cooker is not in use to help keep out the damp, in addition to following the instructions in your Operating manual.

CUSTOMER CARE

In the event you should require spare parts, please order through your esse Dealer.

Should you have cause for dissatisfaction with your cooker, you should contact your esse dealer who will, in most instances, be able to offer you immediate assistance. You will be required to give the following details:

- Your name, address and postcode.
- Your telephone/contact details.
- Clear and concise details of the fault.
- Model and serial number of the cooker (found on the inside panel of the control oven door).
- Purchase date (Please note that a valid purchase receipt or guarantee documentation is required for in-guarantee service calls).

We will then check that we have an accurately completed warranty card, if not then any work carried out will be charged. We will assess the nature of the complaint and either send replacement parts for your dealer to fit, send an engineer to inspect & report, or send an engineer to remedy. If the fault is not actually due to faulty workmanship but some other cause such as misuse or failure to install correctly, a charge will be made to cover the cost of the visit and any new parts required, even during the warranty period. Home visits are made between 08.30 – 17.00hrs Monday to Friday, and are arranged for either a morning or afternoon appointment.



Ouzledale Foundry Co. Limited, Long Ing, Barnoldswick, Lancashire BB18 6BN
Tel: 01282 813235 Fax: 01282 816876 Email: enquiries@esse.com Website: http://www.esse.com



INTRODUCTION

We are pleased that you have chosen an ESSE cooker. We would ask that you read the following operating instructions very carefully.

Correctly installed and operated your ESSE cooker will give satisfactory service for many years.

We feel certain that you will enjoy the warmth and comfort of your ESSE cooker and, perhaps more importantly, you will more than enjoy the superb quality of the cooking.

BON APPETIT!

Contents		The Hotplate	Page 6
Your Cooker	Page 3	The Ovens	Page 6
Tools & Accessories	Page 3	Temperature Settings	Page 7
Before Using Your Cooker	Page 4	The Programmer	Page 8
Lighting the Burner	Page 5	Tips from the ESSE Kitchen	Page 11
To Turn the Burner Off	Page 6	Guarantee	Page 12

IMPORTANT

Warning

The use of a gas appliance results in the production of heat and moisture in the room in which it is installed. Ensure that the room is well ventilated.

Temperatures in cabinet storage spaces above the appliance may be unsafe for storage of some types of materials such as volatile liquids or aerosol sprays which can explode.

Incorrect Operation

The cooker must only be used in the manner described. Incorrect operation can lead to hazards.

This appliance must be used in manual mode only in emergency. Normally an electricity supply is required to operate in timer mode.

Ventilation

The ventilation arrangements will be made by the installer. Never alter these arrangements by blocking off any permanent air vents provided by the installer. Keep natural ventilation holes open or install a mechanical ventilation device (e.g. mechanical extractor hood). Prolonged intensive

use of the appliance may call for added ventilation, for example, increasing the level of mechanical ventilation where present.

Flue Box Plug

It is not recommended to use the flue box plug to stand saucepans, etc on as they may become dislodged raising or lowering the hotplate covers.

Burner Flame Viewing Window

Take care to avoid touching the viewing window or its immediate vicinity when the cooker is alight. These parts may be hot.

Spillage of Combustion

If the cooker is operated under conditions where there is insufficient air in the room, the special pilot fitted to the cooker will cause the burner to shut down. If this occurs, consult your installer for remedial action.

Combustion Vents

Never block or partially cover the combustion vents on either side of the flue box (fig.1).

YOUR COOKER

Your CAT Enabled cooker is a combination appliance, providing hotplate and fast and slow ovens. A single burner is located under the left hand end of the hotplate.

This cooker uses the latest catalytic technology to 'scrub clean' the burnt gas emissions from the burner so it does not need a flue to vent them outside.

There are two hinged covers to conserve heat losses from the hotplate when it is not in use.

Your Cooker - Fig.1

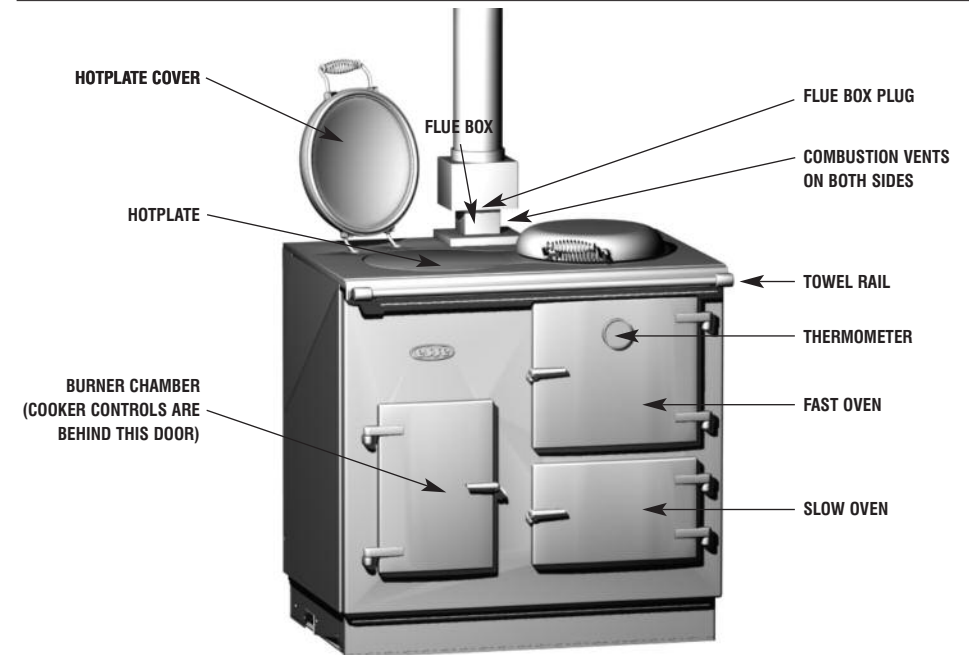

Tools and Accessories

The following items are supplied with your ESSE handle should it be necessary to remove the hotplate for any reason.

Hotplate lifting tools - For lifting off the hotplate.

Oven Accessories - Roasting Tin, Baking Tray and Two Wire Shelves.

The hotplate lifting tools screw into the small holes near the end of the hotplate to provide a lifting

handle should it be necessary to remove the hotplate for any reason.

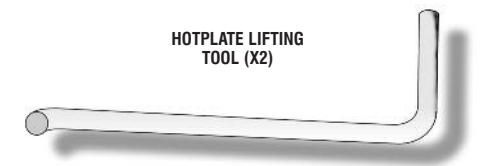

BEFORE USING YOUR COOKER

Check that the plastic protection coating has been removed from each hotplate cover, and from the inside of the oven doors. This should have been done during installation but if the plastic has been left on it will melt on firing the cooker and cause damage to the hotplate covers and oven doors.

The hotplate surface should be wiped with a dishcloth or similar, which has been soaked with hot water and a detergent liquid. Finally dry off the hotplate with an absorbent material.

Nominal Heat Input

The nominal input, based on the gross calorific value of the fuel, is 5.6kW for Natural gas. For propane, gas consumption is 365 gram/hour on high.

Burner Control

The cooker is normally controlled by a 7 day electronic timer and a control valve. When the programmer is not calling for heat the burner does not go off completely but goes down to a 'simmering' position (approx. 1.25kW Natural gas, 1.1kW Propane). This keeps the cooker warm to help reduce the possibility of condensation occurring from cold. Once the pilot is alight, it is recommended that the gas control is set to normal cooking temperature around setting 5 or 6 and the programmer set to come on 45 to 60 minutes

Gas Controls - Fig.2

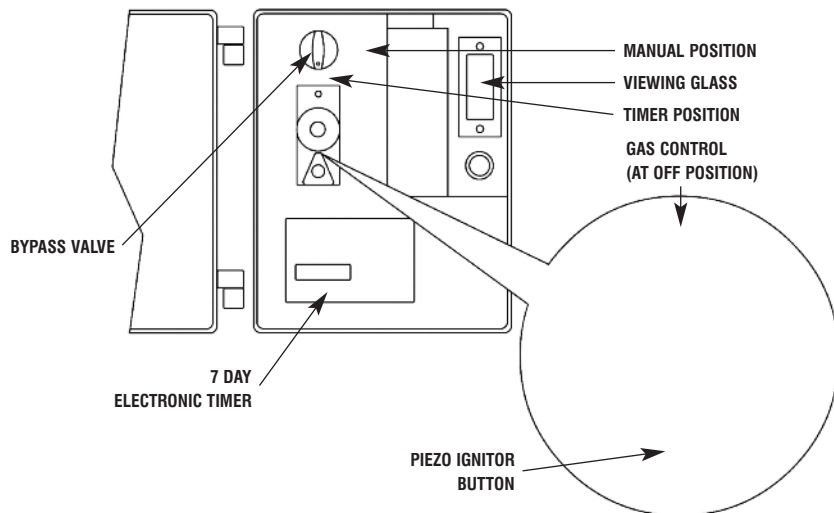

before you start to cook (up to 3 times a day). A by-pass valve is fitted for use in event of electrical power not being available. The by-pass valve should normally be in the **TIMER** position. These controls are located behind the burner chamber door (Fig 2.)

An alternative way of cooking if you do not want to use the programmer or electrical power not being available, is to simply leave the cooker on gas control setting 1 or 2 all the time then turn the gas control up to the normal cooking temperature around setting 5 or 6, 45 to 60 minutes before you start to cook. The by-pass valve should be in the **Manual** position.

The control system operates as follows:-

The knob is turned to the lighting position, depressed and the pilot ignited by the ignitor. With the pilot alight, the knob is released and then turned to an **ON** position.

The temperature of the oven is controlled by a thermostat located in the top oven. The control valve contains a flame failure device that shuts off gas to the burner if the pilot is extinguished for any reason. Detailed operation of the control is dealt with later in these instructions under the appropriate headings.

LIGHTING THE BURNER

To Light the Pilot

Open the burner chamber door fully.

- 1) Turn control knob to **PILOT IGNITION** (Fig 3.)
- 2) Press knob fully downwards and hold it in.
- 3) Press ignitor button fully downwards and release to obtain a spark (holding this button down serves no purpose). Repeat until the pilot lights and flame can be seen through the sight glass.
- 4) Continue to hold the knob in for about 10 seconds (a slow count of one to ten) after the pilot ignites (flame becomes established). Release Knob.

If the pilot goes out - repeat steps 2, 3 & 4.

To Light the Burner

- 5) Ensure that the by-pass valve is in the **TIMER** position. With the electronic timer calling for heat and with the pilot alight, turn control knob to **FULL FLAME POSITION** - See Fig 3, and allow the cooker to heat up for about 45 minutes. If electrical power is not available turn the by-pass valve to manual position to light the burner.
- 6) Turn the control knob to the position required to maintain the oven temperature - (see Using The Oven - page 6).

IMPORTANT

Should the burner and pilot go out at any time, or are turned off by accident, wait at least **TWO MINUTES** before attempting to relight the pilot flame.

This period of time will ensure that the safety device within the gas control has cooled and closed, preventing gas flowing to the burner.

Control Valve Knob Settings - Fig.3

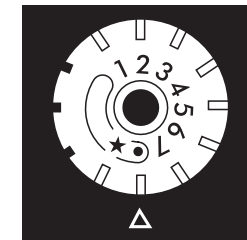

OFF POSITION

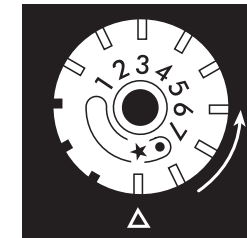

PILOT IGNITION POSITION

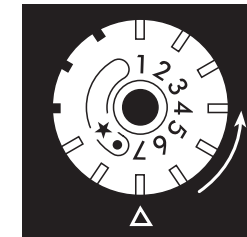

FULL FLAME POSITION

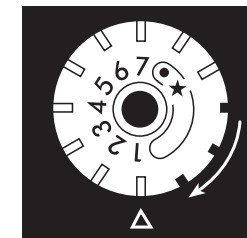

LOW FLAME POSITION

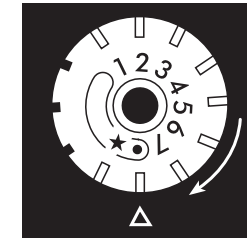

OFF POSITION

NOTE

When lighting the burner for the first time or when the cooker is completely cold, there will be some steam or condensation due to the mass of cold metal. During this warm up period the hotplate covers should be raised to prevent condensation entering the covers.

POSITION to leave the burner **OFF** and the pilot alight. Alternatively the burner may be controlled by the electronic timer. Turn the control knob to the **OFF POSITION** for complete shutdown - (Fig 3.)

Oven Temperatures

The approximate temperature at the various knob setting positions are as shown in Fig 4.

Oven Control, Shown in Pilot Ignition Position - Fig.4

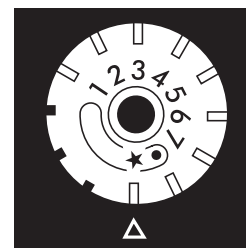

NOTE

The thermometer should be used as a general guide but may vary from the temperatures indicated above. The thermostat will give repeatable oven temperatures when cooking. Approximate equivalent Celsius/Fahrenheit and 'Gas Mark' temperatures are indicated in the following chart. If the oven temperatures are not repeatable, this may indicate that the thermostat requires replacing.

To Turn the Burner Off

Turn the control knob to the **PILOT IGNITION**

THE HOTPLATE

The hotplate is surface ground and intended for use with machined base utensils. As heat passes from the hotplate to utensil almost directly by conduction, good contact is essential and a thin bottomed utensil will result in poor heating performance, especially if the bottom is uneven.

The hottest part of the hotplate is the left hand end. The temperature of the hotplate depends on the

oven control setting. In general the higher the oven temperature the higher the hotplate temperature.

Always keep hotplate covers down except when using the hotplate.

IMPORTANT

The hotplate must not be removed from the cooker, unless the controls are at OFF and the cooker isolated from the mains electricity supply.

TEMPERATURE SETTINGS

Knob settings between any two numbers can be used if required.

Knob Position	Approx. Top Oven °C
1	100
2	130
3	150
4	170
5	200
6	235
7	270

The equivalent gas cooker 'Marks' often quoted in cooking instructions are shown below.

OVEN TEMPERATURE CHART

	°F	°C	G.M.
Very Cool	225	110	1/4
	250	130	1/2
Cool	275	140	1
	300	150	2
Moderate	325	170	3
	350	180	4
Moderately Hot	375	190	5
	400	200	6
Hot	425	220	7
	450	230	8
Very Hot	475	240	9

THE OVENS

NOTE

When food is heated it produces steam similar to a boiling kettle. The ovens are vented to allow some of this steam to escape. However always stand back from the cooker when opening an oven door to allow any build up of steam or heat to release. If steam comes into contact with a cooker surface, e.g. cast front or door or inside the thermometer dial it may condense and produce water droplets. This is quite normal and is not caused by a fault on the cooker.

Do not allow the cooker burner to run for prolonged periods with the top oven door open.

and pull out the oven.

The top oven has four runner positions for the shelves. The wire shelf is used when cooking two trays of food at one time. Certain cooking operations can be carried out by placing dishes directly on the oven bottom. The oven temperature is controlled thermostatically in accordance with the setting selected on the cooker control knob. A thermometer in the door gives an indication of the oven temperature, but since it is in the door itself, the thermometer will react if the door is opened and the thermometer reading may fall considerably. When the door is closed, the thermometer will recover slowly to indicate the oven temperature. A rapid fall in thermometer reading therefore does not indicate that the oven temperature has also done so. The bottom oven takes its heat from the underside of the top oven, and is approximately 3/5 of the top oven temperature.

The top oven will reach operating temperatures in about 75 minutes from cold or 45 to 60 minutes if previously idling at low flame. The most economical control setting will be found by practical usage, but obviously the lower the temperature setting the greater the economy of operation. Remember that the cooker should only be turned to 'Low' and not 'Off' completely when not in use. This is to reduce the possibility of condensation occurring when using the cooker from cold. The electronic timer should be set to suit your requirements.

Routine Servicing

Like any other gas appliance, the cooker must be regularly serviced by a qualified service engineer at least once a year. This will ensure that the cooker remains in a first class and safe condition. Your installer will normally be able to recommend where service can be obtained.

NOTE

On completion of the service, the engineer should fill in the Service Record section of the Installation Instructions. As well as issuing you with the relevant Corgi paperwork for your appliance.

THE PROGRAMMER

Front View of Single Channel Programmer

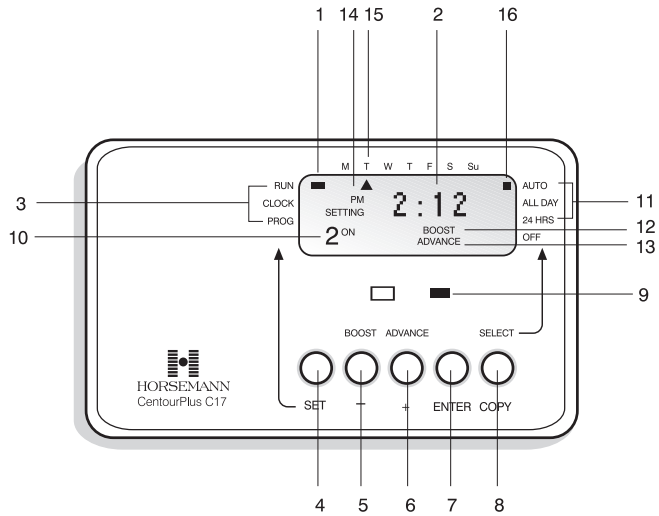

- 1. SET indicator
- 2. Time of day
- 3. Switch Period Symbol
- 4. SET button
- 5. BOOST or adjust (-) button
- 6. ADVANCE or adjust (+) button
- 7. ENTER button
- 8. SELECT or COPY button
- 9. System ON indicator
- 10. SET positions
- 11. PROGRAMME positions
- 12. BOOST symbol
- 13. ADVANCE symbol
- 14. AM/PM symbol
- 15. Day of week indicator
- 16. PROGRAMME indicator

The following are some of the easy to operate features:-

- ❖ 1 Hour Boost.
- ❖ Flexible 7 Day Control.
- ❖ ADVANCE gives instant ON/OFF override.
- ❖ Up to 3 ON/OFF periods per 24 Hr Operation.
- ❖ Programme Options: Auto/All day/24Hr/OFF

Resetting the Programmer

Electronic equipment can in some circumstances be affected by electrical interference. If the programmer's display becomes frozen or scrambled; or if you wish to revert back to the default time settings, please use the following procedure.

NOTE

Press the SET and SELECT buttons together then release the buttons and the programmer will return to preset

Setting Day and Time of Day

The simple instructions below are designed to help with the programming of the unit.

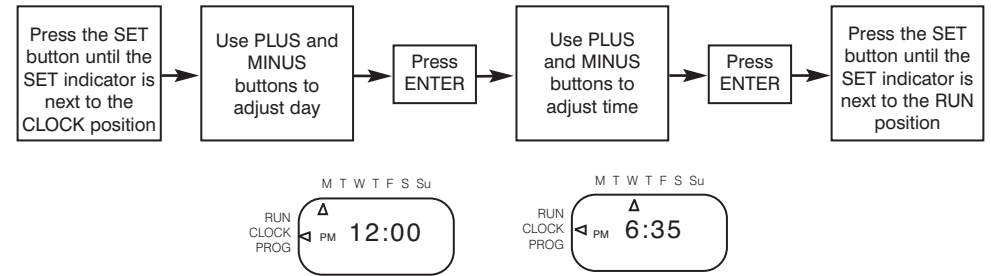

Default Time Settings

The default factory settings are shown, however if you wish to change these proceed as instructed below.

	1ST ON	1ST OFF	2ND ON	2ND OFF	3RD ON	3RD OFF
MON - FRI	6.30 AM	8.30 AM	12.00 PM	12.00 PM	4.30 PM	10.30 PM
SAT/SUN	7.30 AM	10.30 AM	12.00 PM	12.00 PM	5.00 PM	11.00 PM

Setting the ON and OFF Times

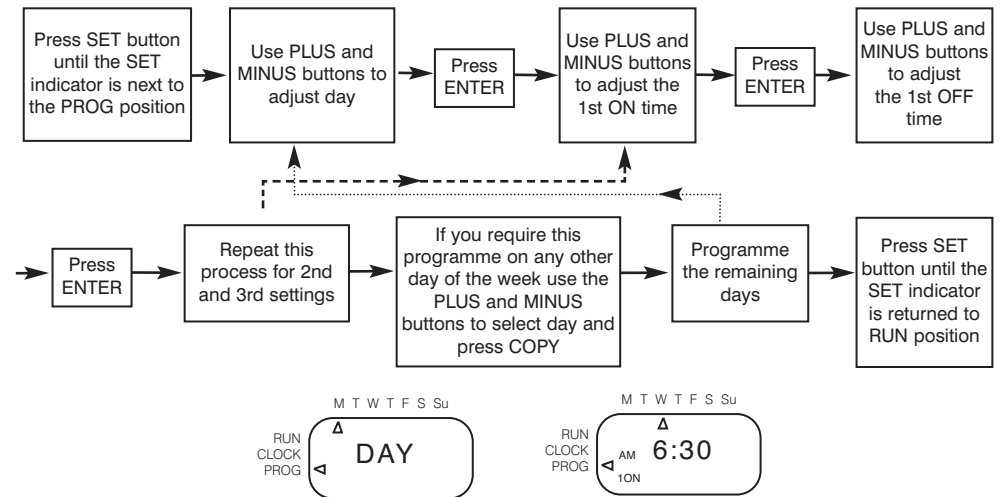

Programming ON/OFF Times

If a period is not required it can be cancelled by setting the ON and OFF settings to the same time. Example ON 10:00am, OFF 10:00am.

Special Features

The SET indicator must remain in the RUN position for the following instructions. See diagram below.

Special Features

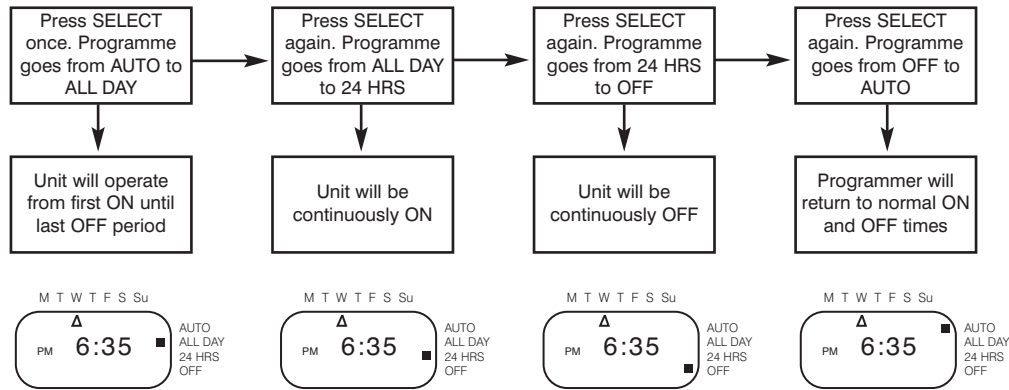

Boost Function - 1 Hour Temporary Override

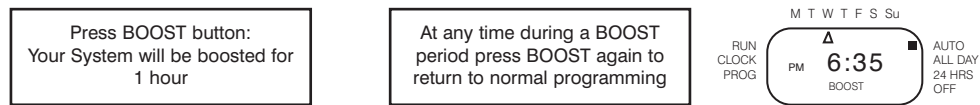

Advance Function - Brings Forward Next On or Off Operation

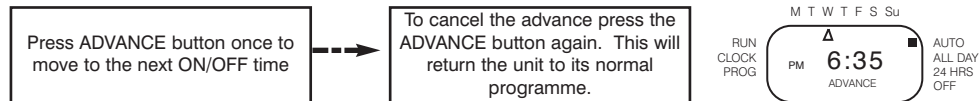

INFORMATION AND ADVICE

The Battery

The programmer is fitted with a non-rechargeable, long life battery, which will maintain the programmed time settings for a minimum of ten months with the supply disconnected. This should be sufficient to power interruptions during the life of the unit.

During power interruptions the display will be blank, after 3 days the current time of day will be lost. These measures are to prolong the battery life.

Service and Repair

This programmer is NOT user serviceable. Please do not dismantle the unit. In the unlikely event of a fault developing please refer to the **Resetting the Programmer** section of this user guide located on page 12. If this fails to resolve the problem please contact a local heating engineer or a qualified electrician.

QUESTIONS AND ANSWERS

The unit display has become frozen.	This could be due to local electrical interference. Using the RESET procedure may rectify the fault.
The indicator neon fails to illuminate.	Using the RESET procedure may rectify the fault. If the problem persists the programmer will need replacing.
There is no display on the programmer.	Try the RESET procedure on page 8, if this fails to rectify the problem please have the mains supply checked.
How do I know if the programmer is still under warranty?	The CentaurPlus range comes with a 2 year guarantee from the date of manufacture. This date is located on the rear of the unit, indicated by a month over a year.
How is the programmer removed?	WARNING: The CentaurPlus programmer must only be removed from it's backplate by either a qualified electrician or heating engineer; The programmer plugs into a 6 pin backplate located on the rear of the unit and is secured using 2 screws located on the bottom surface of the unit. Undo these screws and pull forward and down in an arc motion.

TIPS FROM THE ESSE KITCHEN

Enamel Cleaning

Enamel is simply a coloured glass coating added to the metal to give a durable and hygienic finish. It can be damaged by scratching or by a sudden application of cold liquids onto its surface when hot. Clean with a cloth and soapy water, preferably while cooker is still warm. Proprietary non-scratch liquid cleaners for enamelled surfaces may be used. Spilled liquids should be removed as soon as possible. Fruit juices and other acidic products can remove the gloss surface from the enamel if left for any length of time.

Pots and Pans

It is important to use pots and pans that have a ground base and are flat-bottomed on the hotplate. Cookware made of stainless steel, cast iron, aluminium, glass and earthenware is suitable for your ESSE.

The Hotplate

The temperature versatility here is very important - the area of the hotplate over the left hand end burner is the hottest, while the area over the oven

is cooler. Quick boil on the former and then transfer for simmering on the latter.

For deep fat frying, bring to temperature on the 'right' side. Introduce cold food and then return to temperature on the 'hotter' left side.

Cooking directly on the hotplate is another facility - griddle scones, burgers, sausages, steaks, and even Welsh Rarebit can be cooked directly on the surface.

Meringues can be dried on a baking tray sitting on the hob overnight.

Additionally, by using a barbecue griller you can produce your own toasted sandwiches on the oven top.

The hotplate can be rubbed down with a proprietary cleaning pad if necessary, but normally should need no attention unless spillage is allowed to harden on its surface.

Care must always be taken when handling foods in the home. Always follow the basic rules of food hygiene to prevent bacterial and microbial growth and cross contamination when defrosting, cooking, cooling and freezing foods.